

| | | | | | | 1 | 3A |
|----------------------------|-------------------|------------------|------|---------|--------|---------------------|-------------|
| | | | | | | Qty. | In Assembly |
| 3A | TS1-1/2X1-1/2X1/8 | ASTM A554 GR.304 | 1 | 11'-11" | 807 | 25 | |
| MARK | SIZE | GRADE | QTY. | LENGTH | AREA | WEIGHT | |
| MATERIAL LIST FOR WORKSHOP | | | | | TOTALS | 807 in ² | 25 lb/ft |

| | | | | |
|---------------------------------------|-----------------------|------------|---------------|------------|
| MARTIN'S METAL FABRICATION | DRAWING No. 3A | | | |
| | JOB No. | 210468 | DESCRIPTION | |
| | DRAWN BY | MF | REVISION No. | 1 |
| | DATE DRAWN | 01/04/2022 | REVISION DATE | 01/04/2022 |

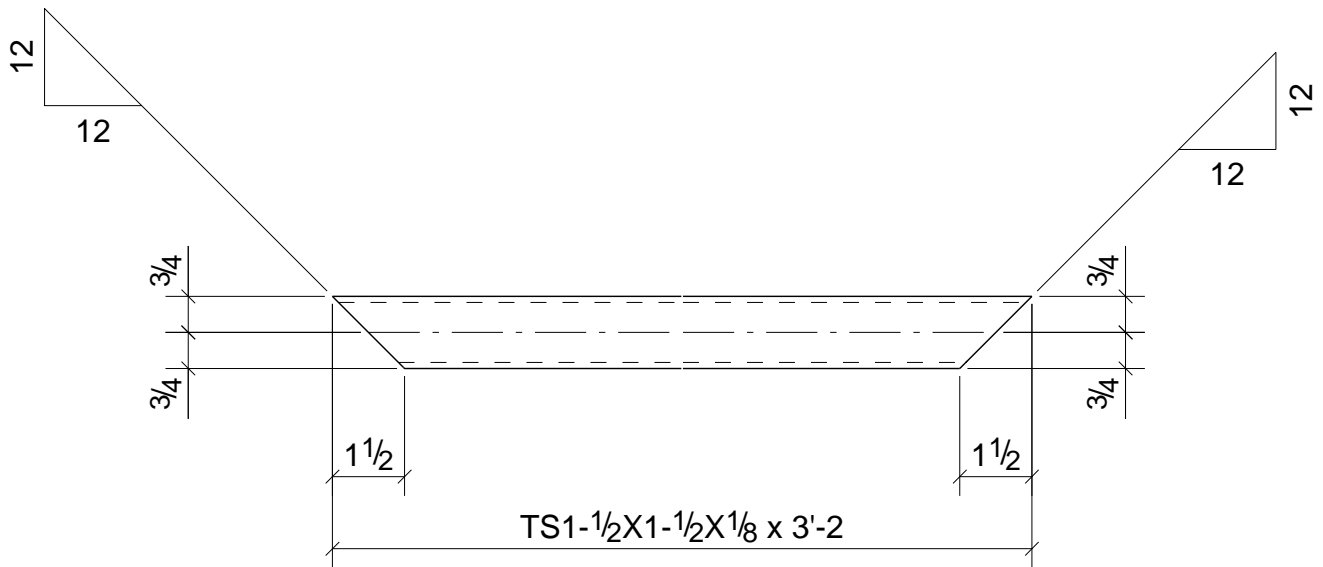

| | | | | | | | |
|----------------------------|-------------------|------------------|------|--------|--------|---------------------|---------|
| 6A | TS1-1/2X1-1/2X1/8 | ASTM A554 GR.304 | 1 | 3'-2" | 214 | 7 | |
| MARK | SIZE | GRADE | QTY. | LENGTH | AREA | WEIGHT | |
| MATERIAL LIST FOR WORKSHOP | | | | | TOTALS | 214 in ² | 7 lb/ft |

| | |
|------|-------------|
| 1 | 6A |
| Qty. | In Assembly |

| | | |
|---------------------------------------|-----------------------|------------|
| MARTIN'S METAL FABRICATION | DRAWING No. 6A | |
| | JOB No. | 210468 |
| | DRAWN BY | MF |
| | DATE DRAWN | 01/04/2022 |

| | |
|---------------|------------|
| DESCRIPTION | |
| REVISION No. | 1 |
| REVISION DATE | 01/04/2022 |

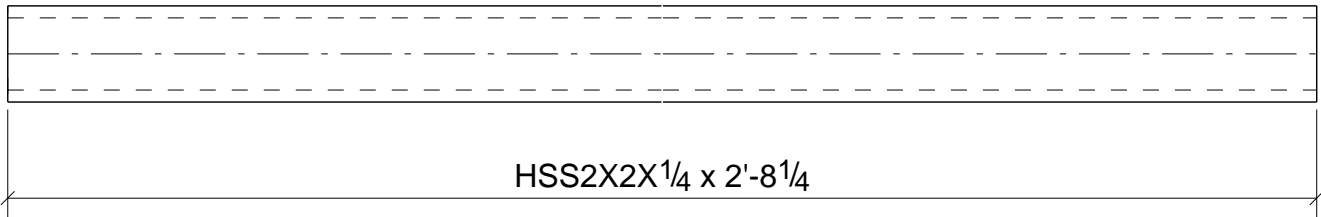

| | | | | | | 1 | 10A |
|----------------------------|------------|------------------|------|-----------|--------|---------------------|-------------|
| | | | | | | Qty. | In Assembly |
| 10A | HSS2X2X1/4 | ASTM A554 GR.304 | 1 | 2'-8 1/4" | 232 | 14 | |
| MARK | SIZE | GRADE | QTY. | LENGTH | AREA | WEIGHT | |
| MATERIAL LIST FOR WORKSHOP | | | | | TOTALS | 232 in ² | 14 lb/ft |

| | | | | |
|---------------------------------------|-------------|------------|---------------|------------|
| MARTIN'S METAL FABRICATION | DRAWING No. | | 10A | |
| | JOB No. | 210468 | DESCRIPTION | |
| | DRAWN BY | MF | REVISION No. | 1 |
| | DATE DRAWN | 01/04/2022 | REVISION DATE | 01/04/2022 |

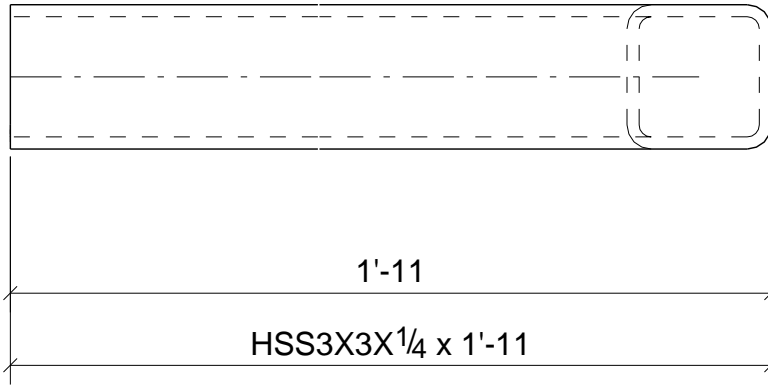
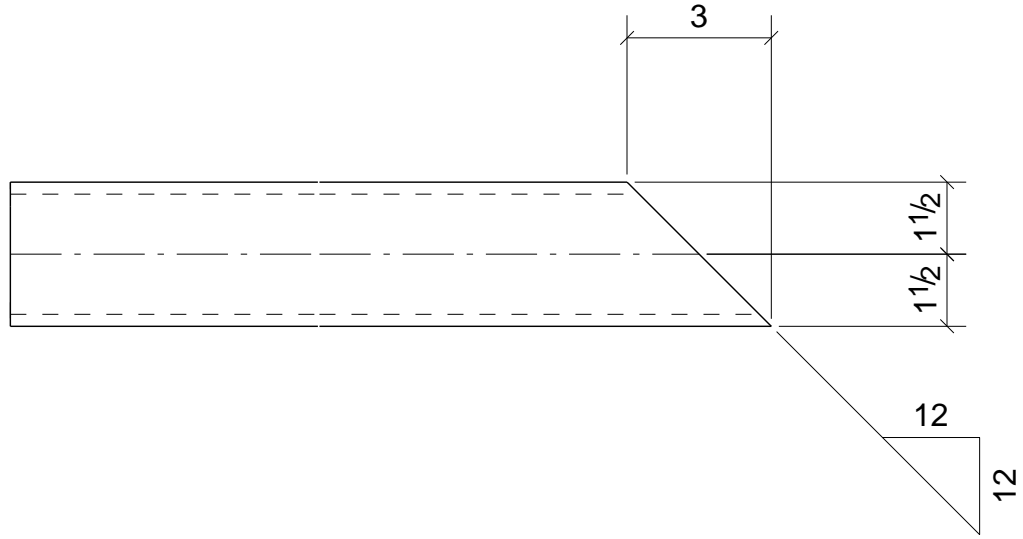

| | |
|------|-------------|
| 2 | 2A |
| Qty. | In Assembly |

| | | | | | | | |
|----------------------------|------------|------------------|------|--------|--------|---------------------|----------|
| p2 | HSS3X3X1/4 | ASTM A554 GR.304 | 2 | 1'-11" | 258 | 16 | |
| MARK | SIZE | GRADE | QTY. | LENGTH | AREA | WEIGHT | |
| MATERIAL LIST FOR WORKSHOP | | | | | TOTALS | 515 in ² | 32 lb/ft |

| | | | | | | |
|---------------------------------------|-------------|------------|---------------|------------|--|--|
| MARTIN'S METAL FABRICATION | DRAWING No. | | p2 | | | |
| | JOB No. | 210468 | DESCRIPTION | | | |
| | DRAWN BY | MF | REVISION No. | 1 | | |
| | DATE DRAWN | 12/22/2021 | REVISION DATE | 01/04/2022 | | |

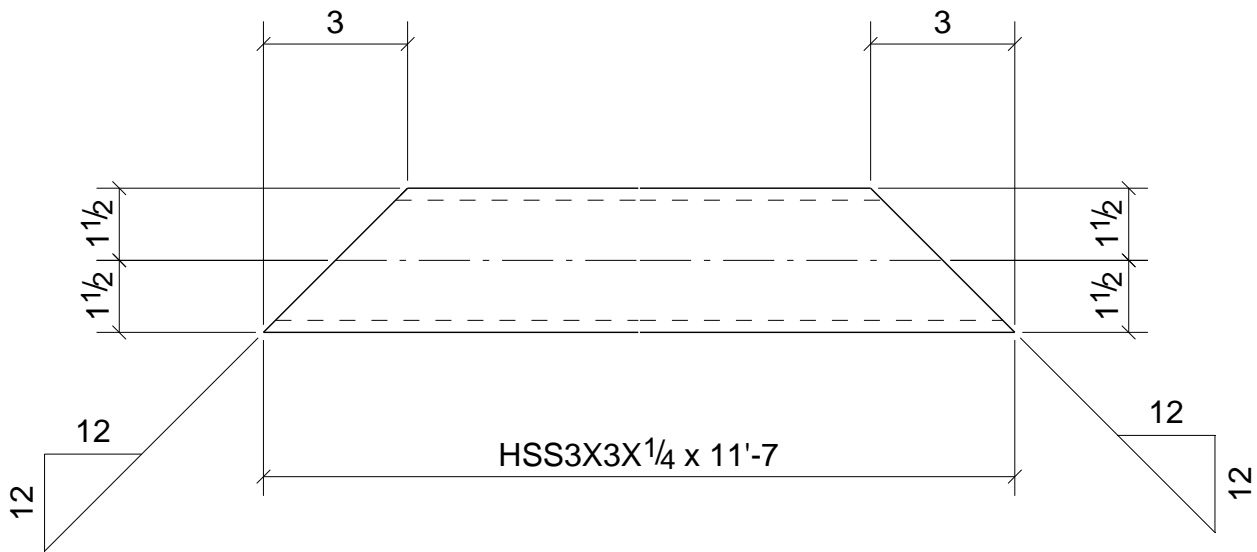

| | | | | | | 1 | 2A |
|----------------------------|------------|------------------|------|--------|--------|----------------------|-------------|
| | | | | | | Qty. | In Assembly |
| p3 | HSS3X3X1/4 | ASTM A554 GR.304 | 1 | 11'-7" | 1556 | 96 | |
| MARK | SIZE | GRADE | QTY. | LENGTH | AREA | WEIGHT | |
| MATERIAL LIST FOR WORKSHOP | | | | | TOTALS | 1556 in ² | 96 lb/ft |

| | | | | |
|---------------------------------------|-------------|------------|---------------|------------|
| MARTIN'S METAL FABRICATION | DRAWING No. | | p3 | |
| | JOB No. | 210468 | DESCRIPTION | |
| | DRAWN BY | MF | REVISION No. | 1 |
| | DATE DRAWN | 12/22/2021 | REVISION DATE | 01/04/2022 |

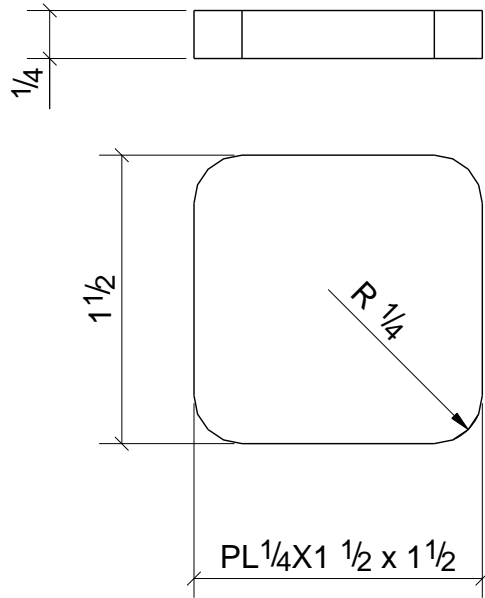

| | |
|------|-------------|
| 5 | 3A |
| 3 | 6A |
| Qty. | In Assembly |

| | | | | | | | |
|----------------------------|---------------|------------------|------|-----------|--------|--------------------|---------|
| p4 | PL1/4"X1 1/2" | ASTM A240 GR.304 | 8 | 0'-1 1/2" | 6 | 0 | |
| MARK | SIZE | GRADE | QTY. | LENGTH | AREA | WEIGHT | |
| MATERIAL LIST FOR WORKSHOP | | | | | TOTALS | 46 in ² | 1 lb/ft |

| | | | | |
|---------------------------------------|-----------------------|------------|---------------|------------|
| MARTIN'S METAL FABRICATION | DRAWING No. p4 | | | |
| | JOB No. | 210468 | DESCRIPTION | |
| | DRAWN BY | MF | REVISION No. | 1 |
| | DATE DRAWN | 12/22/2021 | REVISION DATE | 01/04/2022 |

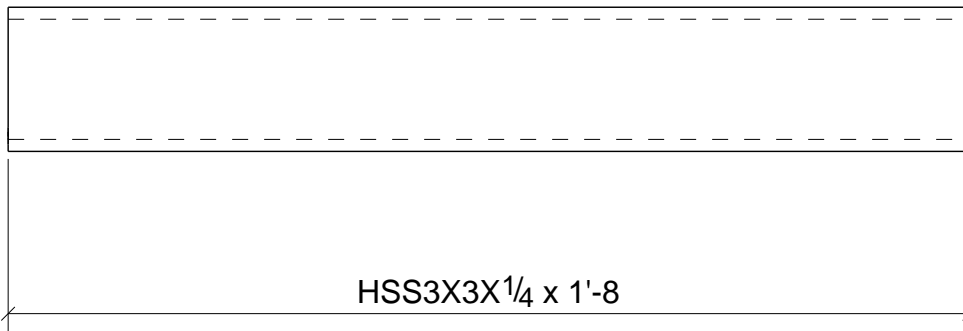

| | | | | | | |
|----------------------------|------------|------------------|------|--------|---------------------|-------------|
| | | | | | 3 | 2A |
| | | | | | Qty. | In Assembly |
| p5 | HSS3X3X1/4 | ASTM A554 GR.304 | 3 | 1'-8" | 224 | 14 |
| MARK | SIZE | GRADE | QTY. | LENGTH | AREA | WEIGHT |
| MATERIAL LIST FOR WORKSHOP | | | | TOTALS | 672 in ² | 42 lb/ft |

| | | | | | | |
|---------------------------------------|-------------|--|------------|---------------|--|------------|
| MARTIN'S METAL FABRICATION | DRAWING No. | | p5 | | | |
| | JOB No. | | 210468 | DESCRIPTION | | |
| | DRAWN BY | | MF | REVISION No. | | 1 |
| | DATE DRAWN | | 12/22/2021 | REVISION DATE | | 01/04/2022 |

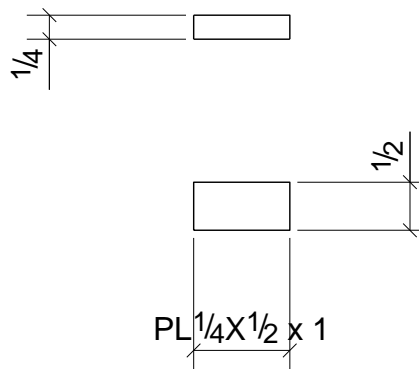

| | | | | | | | |
|----------------------------|-------------|------------------|------|--------|--------|-------------------|-------------|
| | | | | | | 1 | 6A |
| | | | | | | Qty. | In Assembly |
| p7 | PL1/4"X1/2" | ASTM A240 GR.304 | 1 | 0'-1" | 2 | 0 | |
| MARK | SIZE | GRADE | QTY. | LENGTH | AREA | WEIGHT | |
| MATERIAL LIST FOR WORKSHOP | | | | | TOTALS | 2 in ² | 0 lb/ft |

| | | | | |
|---------------------------------------|-------------|------------|---------------|------------|
| MARTIN'S METAL FABRICATION | DRAWING No. | | p7 | |
| | JOB No. | 210468 | DESCRIPTION | |
| | DRAWN BY | MF | REVISION No. | 1 |
| | DATE DRAWN | 12/22/2021 | REVISION DATE | 01/04/2022 |

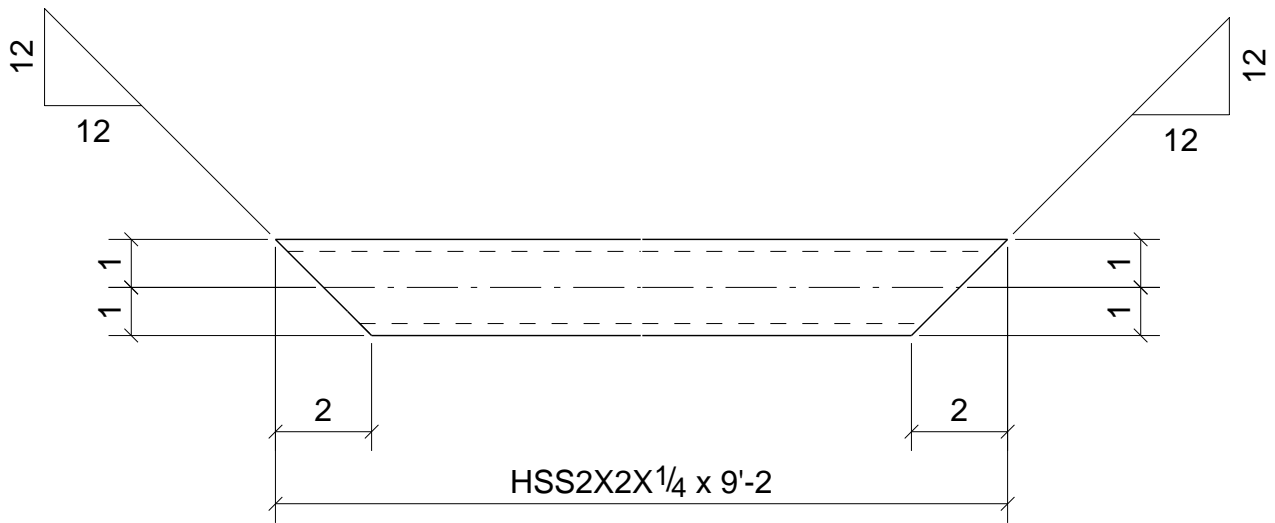

| | | | | | | 1 | 2A |
|----------------------------|------------|------------------|------|--------|--------|---------------------|-------------|
| | | | | | | Qty. | In Assembly |
| p9 | HSS2X2X1/4 | ASTM A554 GR.304 | 1 | 9'-2" | 792 | 47 | |
| MARK | SIZE | GRADE | QTY. | LENGTH | AREA | WEIGHT | |
| MATERIAL LIST FOR WORKSHOP | | | | | TOTALS | 792 in ² | 47 lb/ft |

| | | | | |
|---------------------------------------|-------------|------------|---------------|------------|
| MARTIN'S METAL FABRICATION | DRAWING No. | | p9 | |
| | JOB No. | 210468 | DESCRIPTION | |
| | DRAWN BY | MF | REVISION No. | 1 |
| | DATE DRAWN | 12/22/2021 | REVISION DATE | 01/04/2022 |

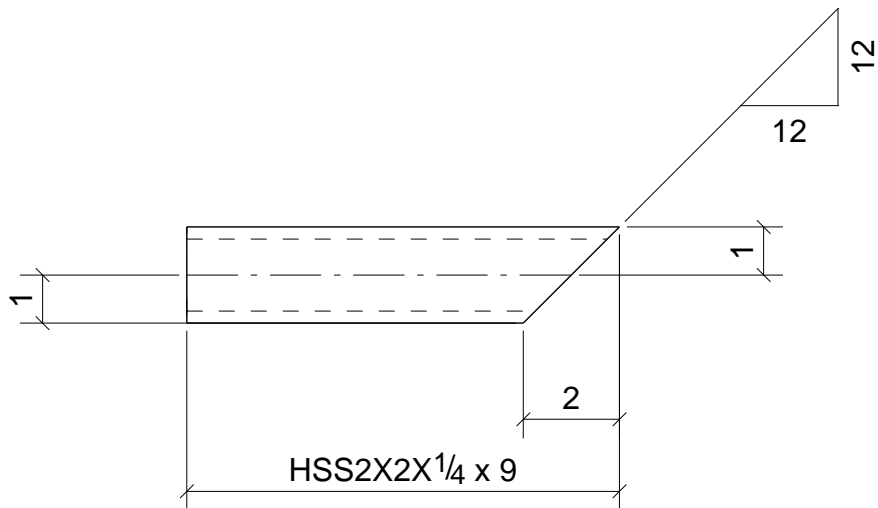

| | | | | | | 2 | 2A |
|----------------------------|------------|------------------|------|--------|--------|---------------------|-------------|
| | | | | | | Qty. | In Assembly |
| p10 | HSS2X2X1/4 | ASTM A554 GR.304 | 2 | 0'-9" | 65 | 4 | |
| MARK | SIZE | GRADE | QTY. | LENGTH | AREA | WEIGHT | |
| MATERIAL LIST FOR WORKSHOP | | | | | TOTALS | 130 in ² | 8 lb/ft |

| | | | | |
|---------------------------------------|-------------|------------|---------------|------------|
| MARTIN'S METAL FABRICATION | DRAWING No. | | p10 | |
| | JOB No. | 210468 | DESCRIPTION | |
| | DRAWN BY | MF | REVISION No. | 1 |
| | DATE DRAWN | 12/22/2021 | REVISION DATE | 01/04/2022 |

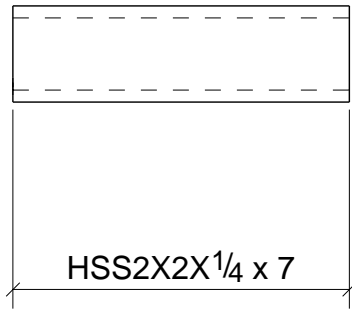

| | | | | | | | |
|----------------------------|------------|------------------|------|--------|--------|---------------------|-------------|
| | | | | | | 2 | 2A |
| | | | | | | Qty. | In Assembly |
| p11 | HSS2X2X1/4 | ASTM A554 GR.304 | 2 | 0'-7" | | 50 | 3 |
| MARK | SIZE | GRADE | QTY. | LENGTH | | AREA | WEIGHT |
| MATERIAL LIST FOR WORKSHOP | | | | | TOTALS | 101 in ² | 6 lb/ft |

| | | | | |
|---------------------------------------|-------------|------------|---------------|------------|
| MARTIN'S METAL FABRICATION | DRAWING No. | | p11 | |
| | JOB No. | 210468 | DESCRIPTION | |
| | DRAWN BY | MF | REVISION No. | 1 |
| | DATE DRAWN | 12/22/2021 | REVISION DATE | 01/04/2022 |

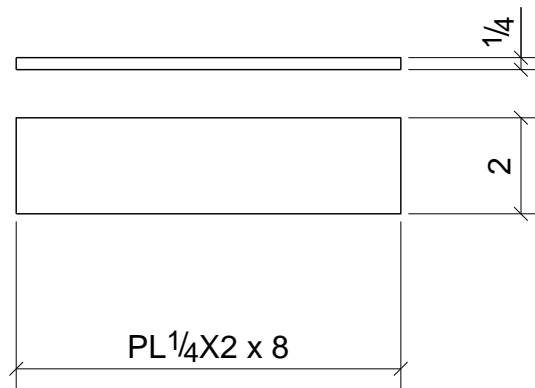

| | | | | | | 2 | 2A |
|----------------------------|-----------|------------------|------|--------|--------|--------------------|-------------|
| | | | | | | Qty. | In Assembly |
| p28 | PL1/4"X2" | ASTM A240 GR.304 | 2 | 0'-8" | 37 | | 1 |
| MARK | SIZE | GRADE | QTY. | LENGTH | AREA | WEIGHT | |
| MATERIAL LIST FOR WORKSHOP | | | | | TOTALS | 74 in ² | 2 lb/ft |

| | | | | |
|---------------------------------------|-------------|------------|---------------|------------|
| MARTIN'S METAL FABRICATION | DRAWING No. | | p28 | |
| | JOB No. | 210468 | DESCRIPTION | |
| | DRAWN BY | MF | REVISION No. | 1 |
| | DATE DRAWN | 12/16/2021 | REVISION DATE | 01/04/2022 |

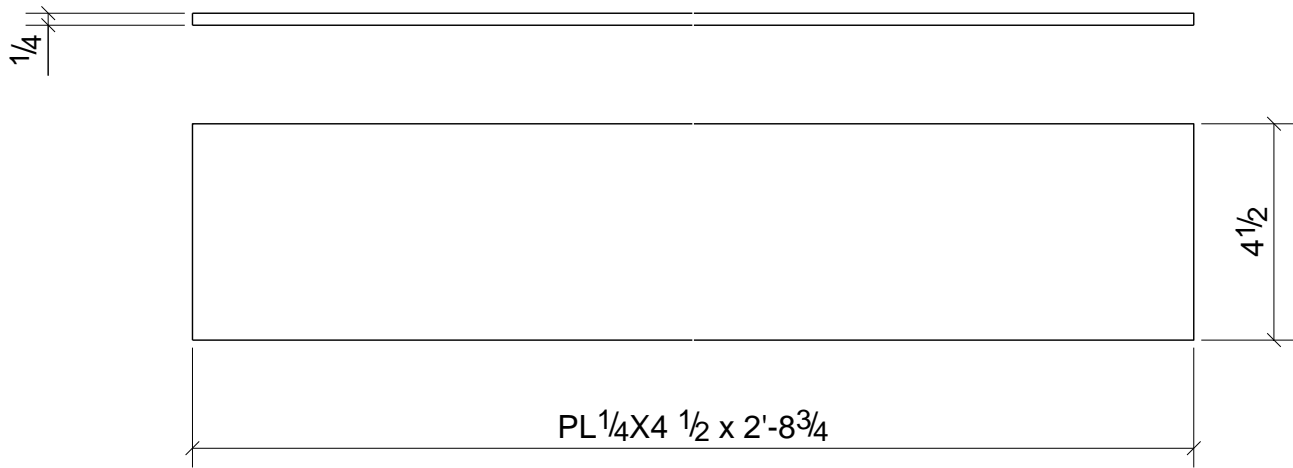

| | | | | | | 1 | 2A | |
|-------------------------------|---------------|------------------|-------------|-----------|------------|---------------------|-------------|------------|
| | | | | | | Qty. | In Assembly | |
| p30 | PL1/4"X4 1/2" | ASTM A240 GR.304 | 1 | 2'-8 3/4" | 313 | 10 | | |
| MARK | SIZE | GRADE | QTY. | LENGTH | AREA | WEIGHT | | |
| MATERIAL LIST FOR WORKSHOP | | | | | TOTALS | 313 in ² | 10 lb/ft | |
| MARTIN'S METAL FABRICATION | | | DRAWING No. | | p30 | | | |
| | | | JOB No. | | 210468 | DESCRIPTION | | |
| | | | DRAWN BY | | MF | REVISION No. | | 1 |
| | | | DATE DRAWN | | 12/16/2021 | REVISION DATE | | 01/04/2022 |

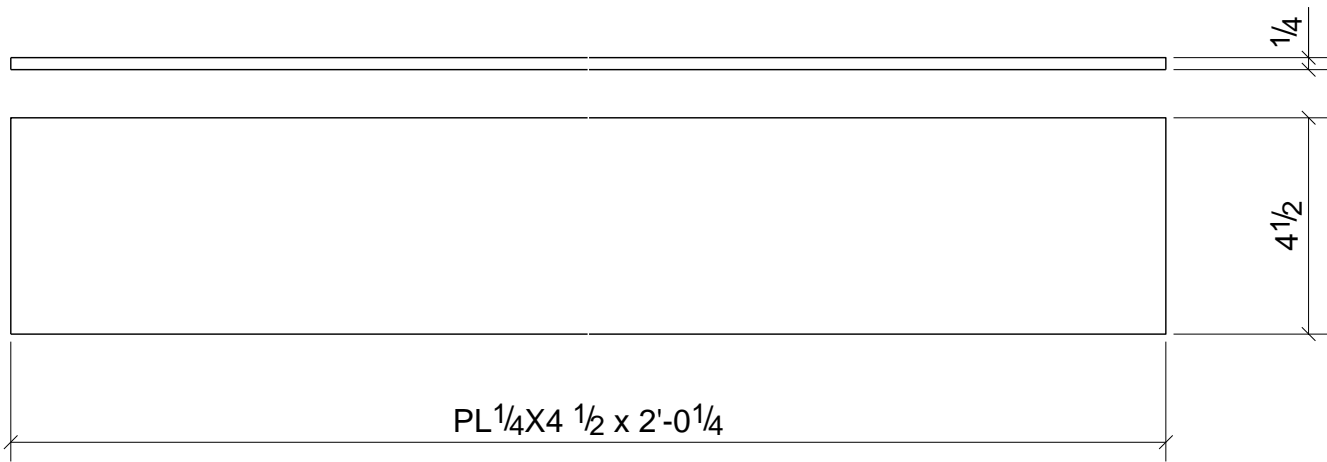

| | | | | | | 1 | 2A |
|----------------------------|---------------|------------------|------|-----------|--------|---------------------|-------------|
| | | | | | | Qty. | In Assembly |
| p31 | PL1/4"X4 1/2" | ASTM A240 GR.304 | 1 | 2'-0 1/4" | 233 | 8 | |
| MARK | SIZE | GRADE | QTY. | LENGTH | AREA | WEIGHT | |
| MATERIAL LIST FOR WORKSHOP | | | | | TOTALS | 233 in ² | 8 lb/ft |

| | | | | |
|---------------------------------------|-------------|------------|---------------|------------|
| MARTIN'S METAL FABRICATION | DRAWING No. | | p31 | |
| | JOB No. | 210468 | DESCRIPTION | |
| | DRAWN BY | MF | REVISION No. | 1 |
| | DATE DRAWN | 12/16/2021 | REVISION DATE | 01/04/2022 |

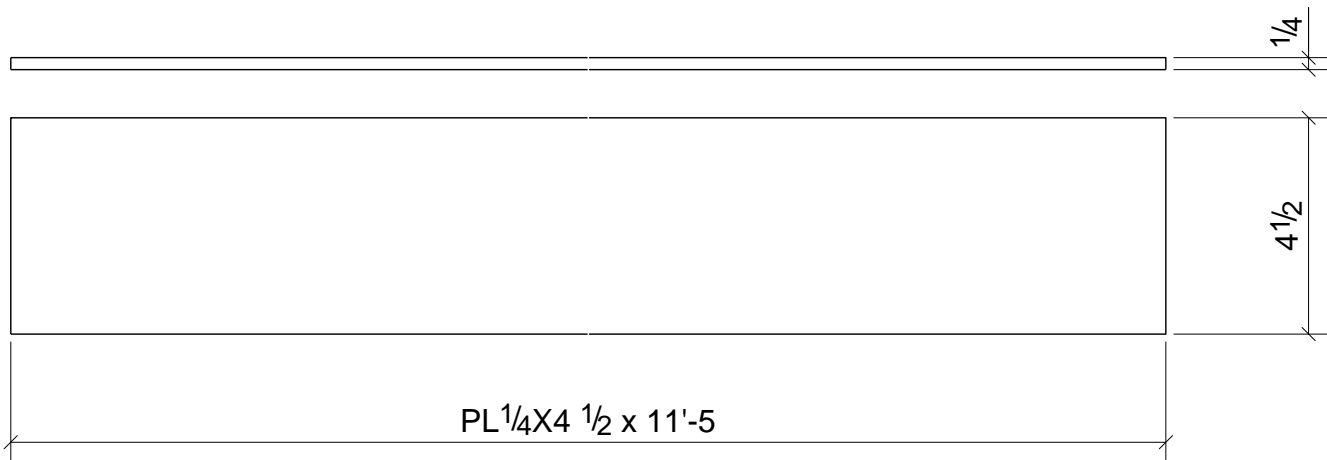

| | | | | | | 1 | 2A |
|----------------------------|---------------|------------------|------|--------|--------|----------------------|-------------|
| | | | | | | Qty. | In Assembly |
| p32 | PL1/4"x4 1/2" | ASTM A240 GR.304 | 1 | 11'-5" | 1304 | 44 | |
| MARK | SIZE | GRADE | QTY. | LENGTH | AREA | WEIGHT | |
| MATERIAL LIST FOR WORKSHOP | | | | | TOTALS | 1304 in ² | 44 lb/ft |

| | | | | |
|---------------------------------------|-------------|------------|---------------|------------|
| MARTIN'S METAL FABRICATION | DRAWING No. | | p32 | |
| | JOB No. | 210468 | DESCRIPTION | |
| | DRAWN BY | MF | REVISION No. | 1 |
| | DATE DRAWN | 12/16/2021 | REVISION DATE | 01/04/2022 |

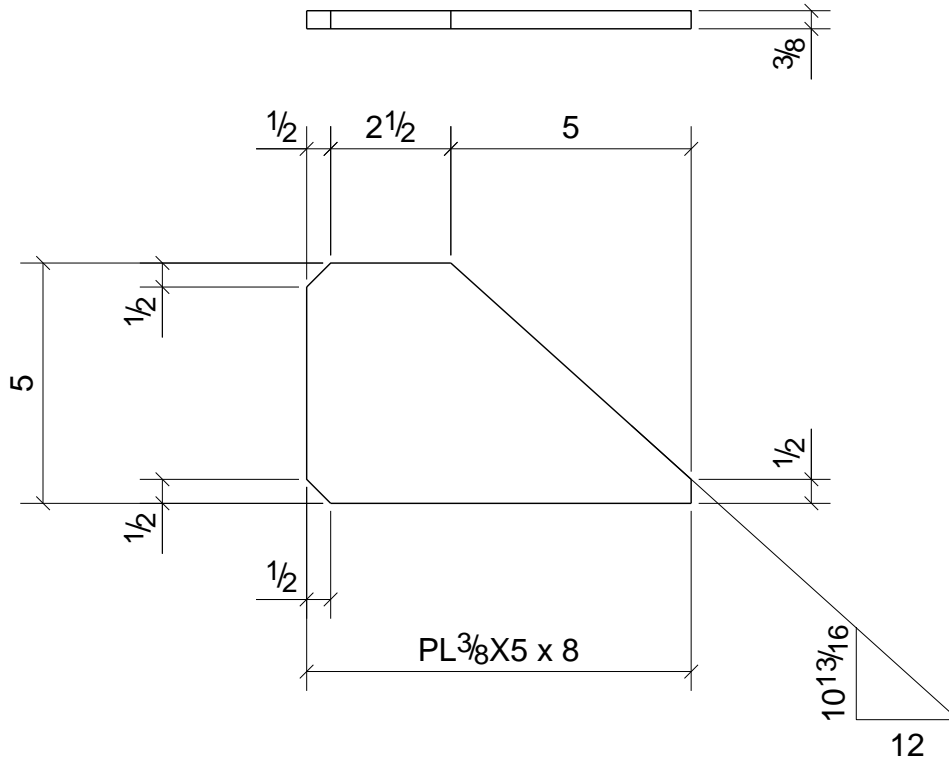

| | | | | | | 1 | 2A |
|----------------------------|-----------|------------------|------|--------|--------|--------------------|-------------|
| | | | | | | Qty. | In Assembly |
| p39 | PL3/8"x5" | ASTM A240 GR.304 | 1 | 0'-8" | 65 | 3 | |
| MARK | SIZE | GRADE | QTY. | LENGTH | AREA | WEIGHT | |
| MATERIAL LIST FOR WORKSHOP | | | | | TOTALS | 65 in ² | 3 lb/ft |

| | | |
|---------------------------------------|------------------------|--------------------------|
| MARTIN'S METAL FABRICATION | DRAWING No. p39 | |
| | JOB No. 210468 | DESCRIPTION |
| | DRAWN BY MF | REVISION No. 1 |
| | DATE DRAWN 12/16/2021 | REVISION DATE 01/04/2022 |

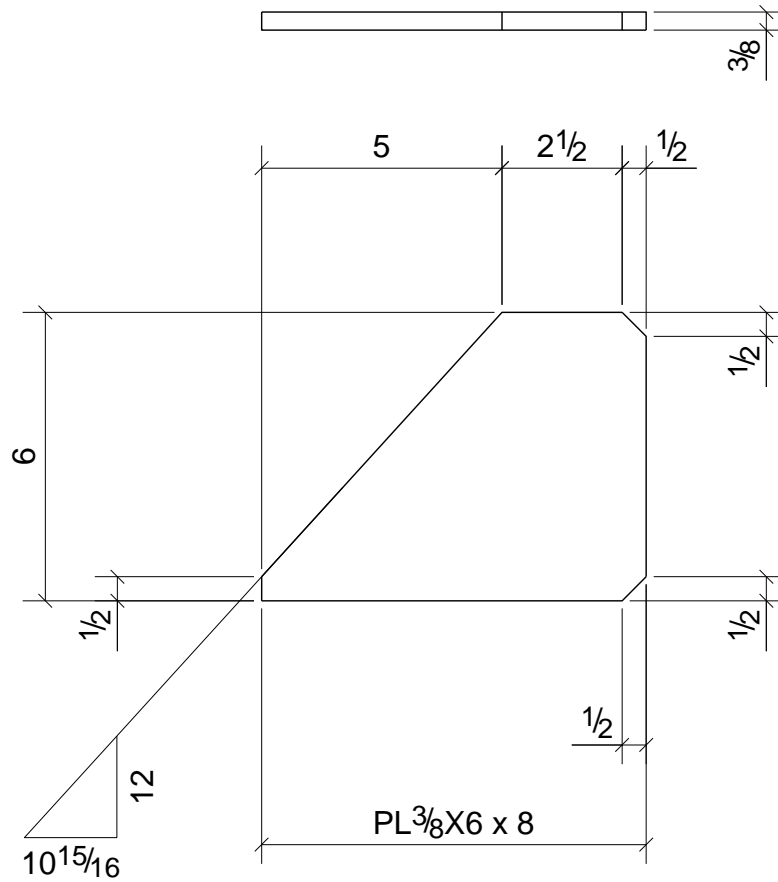

| | |
|------|-------------|
| 1 | 2A |
| Qty. | In Assembly |

| | | | | | | | |
|----------------------------|-----------|------------------|------|--------|--------|--------------------|---------|
| p40 | PL3/8"x6" | ASTM A240 GR.304 | 1 | 0'-8" | 77 | 4 | |
| MARK | SIZE | GRADE | QTY. | LENGTH | AREA | WEIGHT | |
| MATERIAL LIST FOR WORKSHOP | | | | | TOTALS | 77 in ² | 4 lb/ft |

**MARTIN'S METAL
FABRICATION**

DRAWING No.

p40

| | | | |
|------------|------------|---------------|------------|
| JOB No. | 210468 | DESCRIPTION | |
| DRAWN BY | MF | REVISION No. | 1 |
| DATE DRAWN | 12/16/2021 | REVISION DATE | 01/04/2022 |

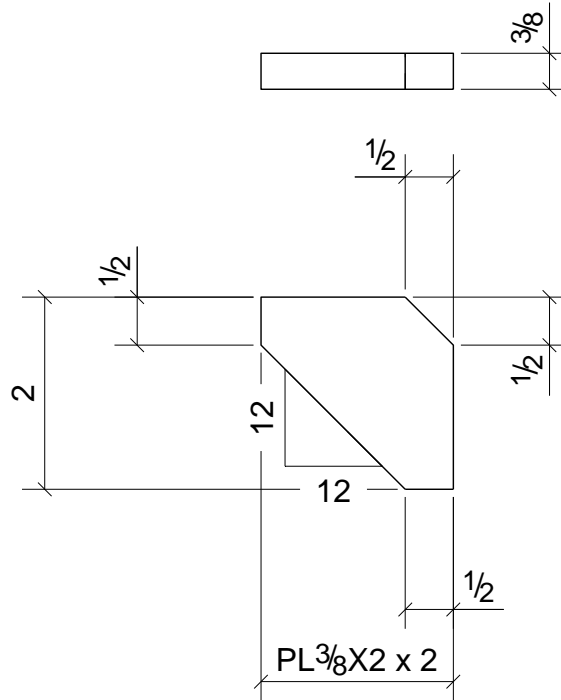

| | | | | | | | |
|----------------------------|-----------|------------------|------|--------|--------|--------------------|---------|
| p41 | PL3/8"X2" | ASTM A240 GR.304 | 4 | 0'-2" | 8 | 0 | |
| MARK | SIZE | GRADE | QTY. | LENGTH | AREA | WEIGHT | |
| MATERIAL LIST FOR WORKSHOP | | | | | TOTALS | 32 in ² | 1 lb/ft |

| | |
|------|-------------|
| 4 | 1A |
| Qty. | In Assembly |

| | | |
|---------------------------------------|------------------------|--------------------------|
| MARTIN'S METAL FABRICATION | DRAWING No. p41 | |
| | JOB No. 210468 | DESCRIPTION |
| | DRAWN BY MF | REVISION No. 1 |
| | DATE DRAWN 12/16/2021 | REVISION DATE 01/04/2022 |

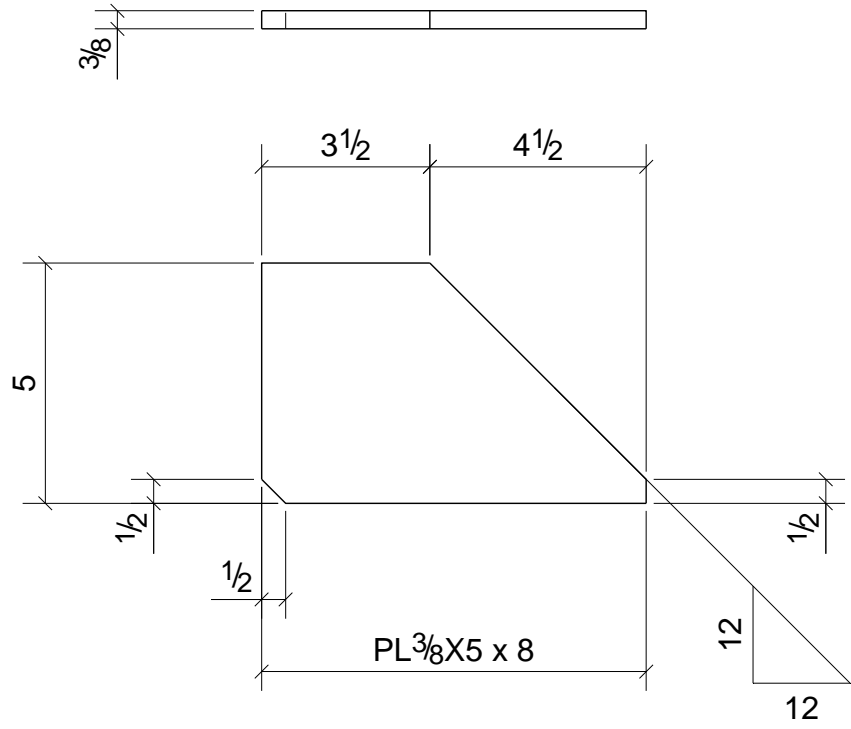

| | | | | | | 1 | 2A |
|----------------------------|-----------|------------------|------|--------|--------------------|---------|-------------|
| | | | | | | Qty. | In Assembly |
| p42 | PL3/8"X5" | ASTM A240 GR.304 | 1 | 0'-8" | 68 | 3 | |
| MARK | SIZE | GRADE | QTY. | LENGTH | AREA | WEIGHT | |
| MATERIAL LIST FOR WORKSHOP | | | | TOTALS | 68 in ² | 3 lb/ft | |

| | | | | |
|---------------------------------------|-------------|------------|---------------|------------|
| MARTIN'S METAL FABRICATION | DRAWING No. | | p42 | |
| | JOB No. | 210468 | DESCRIPTION | |
| | DRAWN BY | MF | REVISION No. | 1 |
| | DATE DRAWN | 12/16/2021 | REVISION DATE | 01/04/2022 |

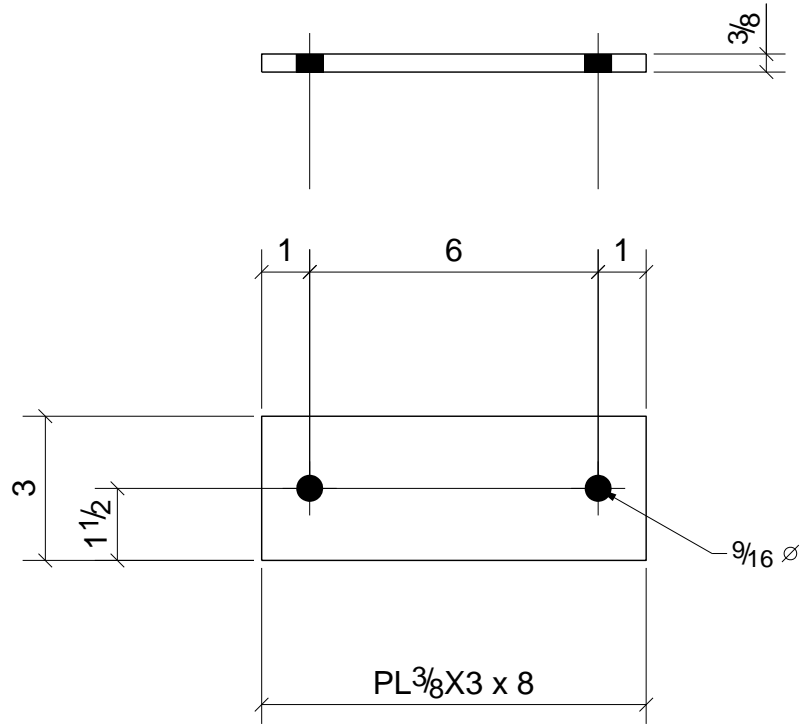

| | | | | | | 1 | 7A |
|----------------------------|-----------------------|------------------|------|--------|--------|--------------------|-------------|
| | | | | | | Qty. | In Assembly |
| p43 | PL $\frac{3}{8}$ "X3" | ASTM A240 GR.304 | 1 | 0'-8" | 56 | 3 | |
| MARK | SIZE | GRADE | QTY. | LENGTH | AREA | WEIGHT | |
| MATERIAL LIST FOR WORKSHOP | | | | | TOTALS | 56 in ² | 3 lb/ft |

| | | | | |
|---------------------------------------|-------------|------------|---------------|------------|
| MARTIN'S METAL FABRICATION | DRAWING No. | | p43 | |
| | JOB No. | 210468 | DESCRIPTION | |
| | DRAWN BY | MF | REVISION No. | 1 |
| | DATE DRAWN | 12/16/2021 | REVISION DATE | 01/04/2022 |

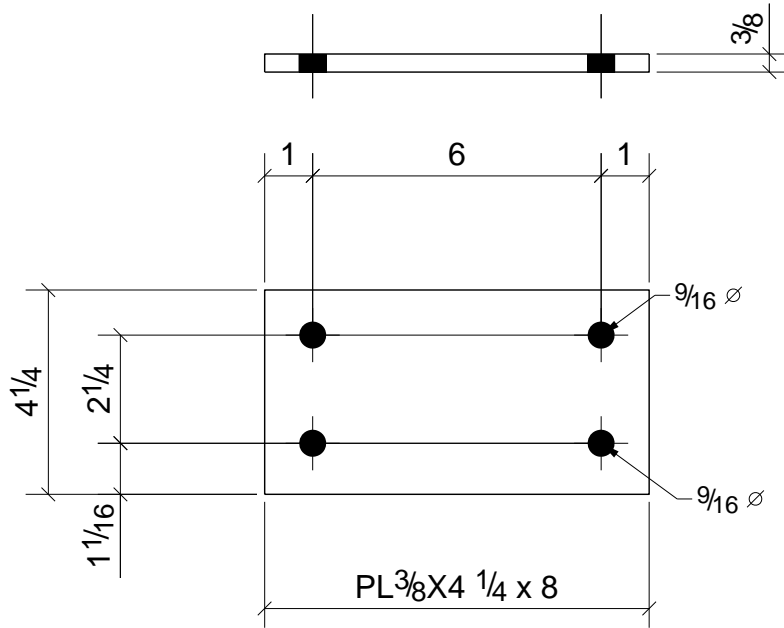

| | |
|------|-------------|
| 1 | 7A |
| Qty. | In Assembly |

| | | | | | | | |
|----------------------------|---------------|------------------|------|--------|--------|--------------------|---------|
| p44 | PL3/8"X4 1/4" | ASTM A240 GR.304 | 1 | 0'-8" | 77 | 4 | |
| MARK | SIZE | GRADE | QTY. | LENGTH | AREA | WEIGHT | |
| MATERIAL LIST FOR WORKSHOP | | | | | TOTALS | 77 in ² | 4 lb/ft |

| | | | |
|---------------------------------------|------------------------|---------------|------------|
| MARTIN'S METAL FABRICATION | DRAWING No. p44 | | |
| | JOB No. | 210468 | |
| | DRAWN BY | MF | |
| | DATE DRAWN | 12/16/2021 | |
| | | DESCRIPTION | |
| | | REVISION No. | 1 |
| | | REVISION DATE | 01/04/2022 |

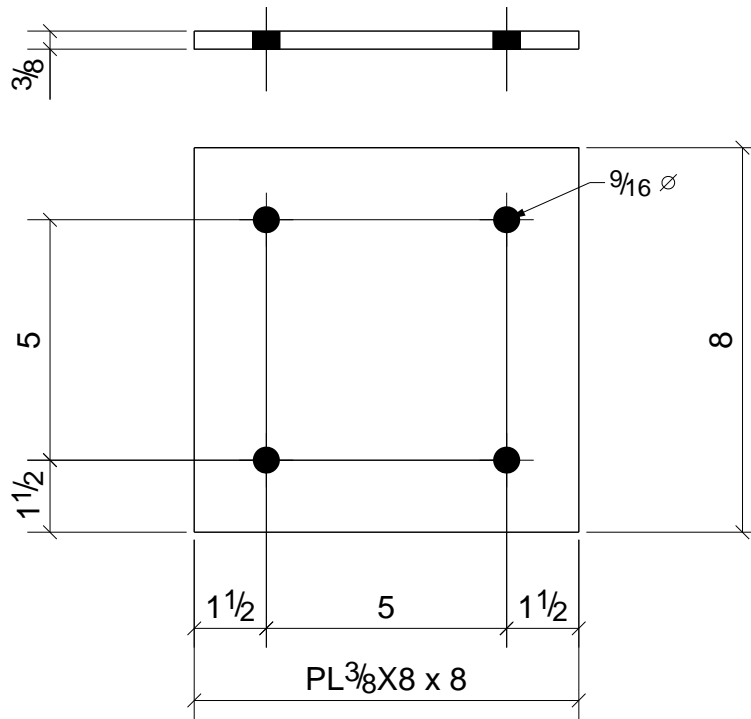

| | |
|------|-------------|
| 1 | 1A |
| 1 | 2A |
| Qty. | In Assembly |

| | | | | | | | |
|----------------------------|-----------------------|------------------|------|--------|--------|---------------------|----------|
| p45 | PL $\frac{3}{8}$ "X8" | ASTM A240 GR.304 | 2 | 0'-8" | 140 | 7 | |
| MARK | SIZE | GRADE | QTY. | LENGTH | AREA | WEIGHT | |
| MATERIAL LIST FOR WORKSHOP | | | | | TOTALS | 280 in ² | 14 lb/ft |

| | | |
|---------------------------------------|------------------------|--------------------------|
| MARTIN'S METAL FABRICATION | DRAWING No. p45 | |
| | JOB No. 210468 | DESCRIPTION |
| | DRAWN BY MF | REVISION No. 1 |
| | DATE DRAWN 12/16/2021 | REVISION DATE 01/04/2022 |

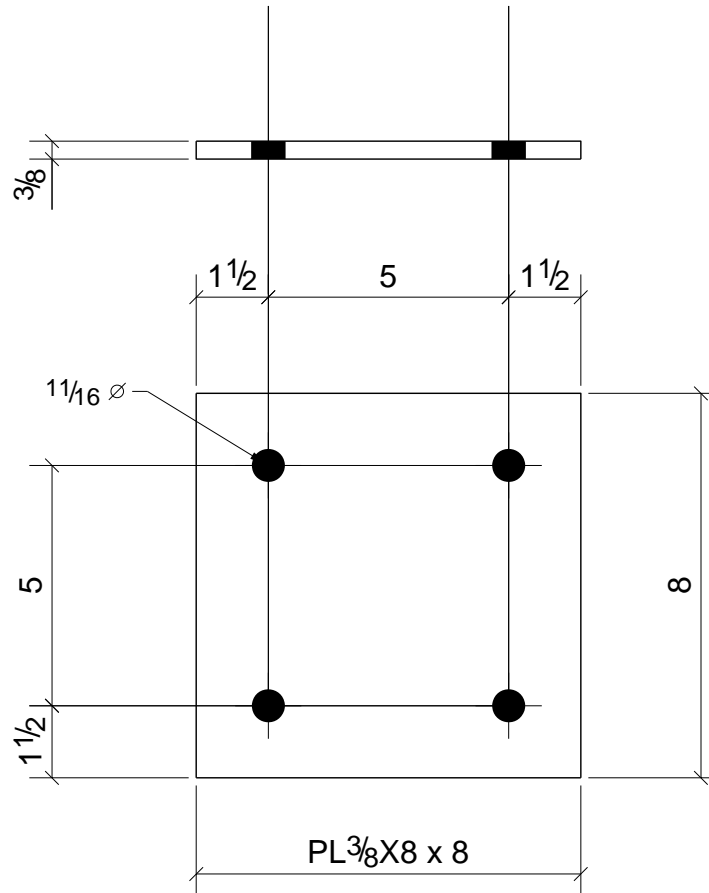

| | | | | | | 1 | 1A |
|----------------------------|-----------|------------------|------|--------|--------|---------------------|-------------|
| | | | | | | Qty. | In Assembly |
| p46 | PL3/8"x8" | ASTM A240 GR.304 | 1 | 0'-8" | 140 | 7 | |
| MARK | SIZE | GRADE | QTY. | LENGTH | AREA | WEIGHT | |
| MATERIAL LIST FOR WORKSHOP | | | | | TOTALS | 140 in ² | 7 lb/ft |

| | | | | |
|---------------------------------------|------------------------|------------|---------------|------------|
| MARTIN'S METAL FABRICATION | DRAWING No. p46 | | | |
| | JOB No. | 210468 | DESCRIPTION | |
| | DRAWN BY | MF | REVISION No. | 1 |
| | DATE DRAWN | 12/16/2021 | REVISION DATE | 01/04/2022 |

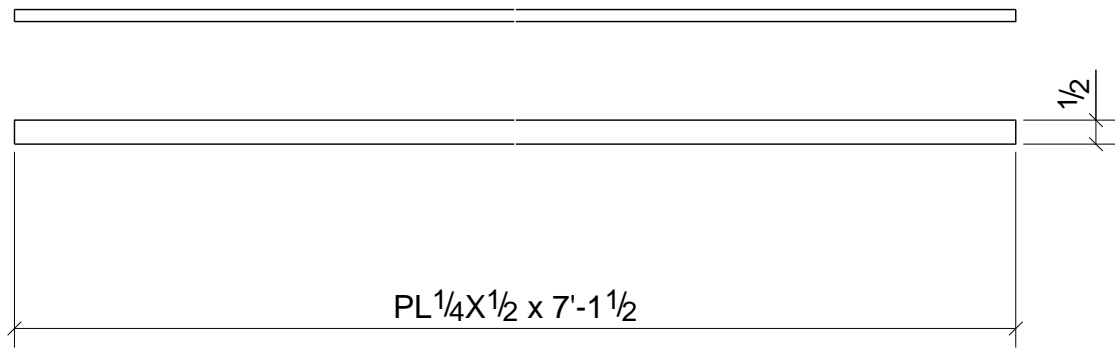

| | | | | | | 1 | 2A |
|----------------------------|-------------|------------------|------|-----------|--------|---------------------|-------------|
| | | | | | | Qty. | In Assembly |
| p48 | PL1/4"X1/2" | ASTM A240 GR.304 | 1 | 7'-1 1/2" | 128 | 3 | |
| MARK | SIZE | GRADE | QTY. | LENGTH | AREA | WEIGHT | |
| MATERIAL LIST FOR WORKSHOP | | | | | TOTALS | 128 in ² | 3 lb/ft |

| | | | | |
|---------------------------------------|-------------|------------|---------------|------------|
| MARTIN'S METAL FABRICATION | DRAWING No. | | p48 | |
| | JOB No. | 210468 | DESCRIPTION | |
| | DRAWN BY | MF | REVISION No. | 1 |
| | DATE DRAWN | 01/04/2022 | REVISION DATE | 01/04/2022 |

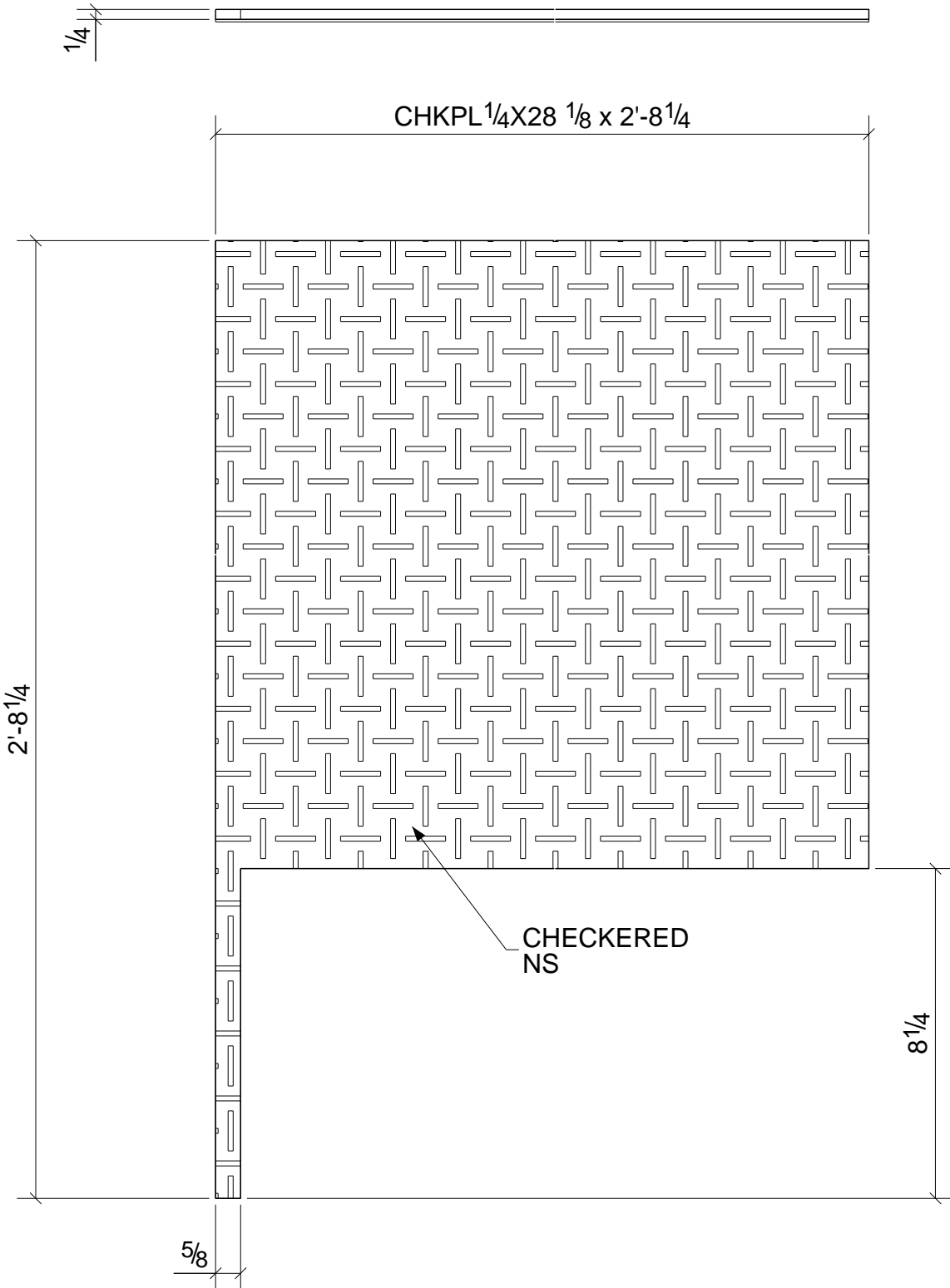

| | | | | 1 | 2A | |
|----------------------------|-------------------|------------------|------|-----------|----------------------|----------|
| | | | | Qty. | In Assembly | |
| p50 | CHKPL1/4"x28 1/8" | ASTM A240 GR.304 | 1 | 2'-8 1/4" | 1390 | 48 |
| MARK | SIZE | GRADE | QTY. | LENGTH | AREA | WEIGHT |
| MATERIAL LIST FOR WORKSHOP | | | | TOTALS | 1390 in ² | 48 lb/ft |

| | | |
|---------------------------------------|------------------------|--------------------------|
| MARTIN'S METAL FABRICATION | DRAWING No. p50 | |
| | JOB No. 210468 | DESCRIPTION |
| | DRAWN BY MF | REVISION No. 1 |
| | DATE DRAWN 12/16/2021 | REVISION DATE 01/04/2022 |

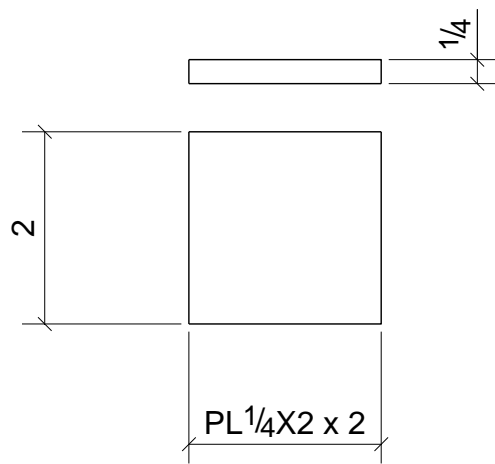

| | |
|------|-------------|
| 2 | 8A |
| 2 | 9A |
| 2 | 10A |
| Qty. | In Assembly |

| | | | | | | | |
|----------------------------|-----------|------------------|------|--------|--------|--------------------|---------|
| p51 | PL1/4"X2" | ASTM A240 GR.304 | 6 | 0'-2" | 10 | 0 | |
| MARK | SIZE | GRADE | QTY. | LENGTH | AREA | WEIGHT | |
| MATERIAL LIST FOR WORKSHOP | | | | | TOTALS | 60 in ² | 2 lb/ft |

| | | | |
|---------------------------------------|------------------------|--------------|---|
| MARTIN'S METAL FABRICATION | DRAWING No. p51 | | |
| | JOB No. | 210468 | |
| | DRAWN BY | MF | |
| | DATE DRAWN | 12/16/2021 | |
| DESCRIPTION | | REVISION No. | 1 |
| REVISION DATE | | 01/04/2022 | |

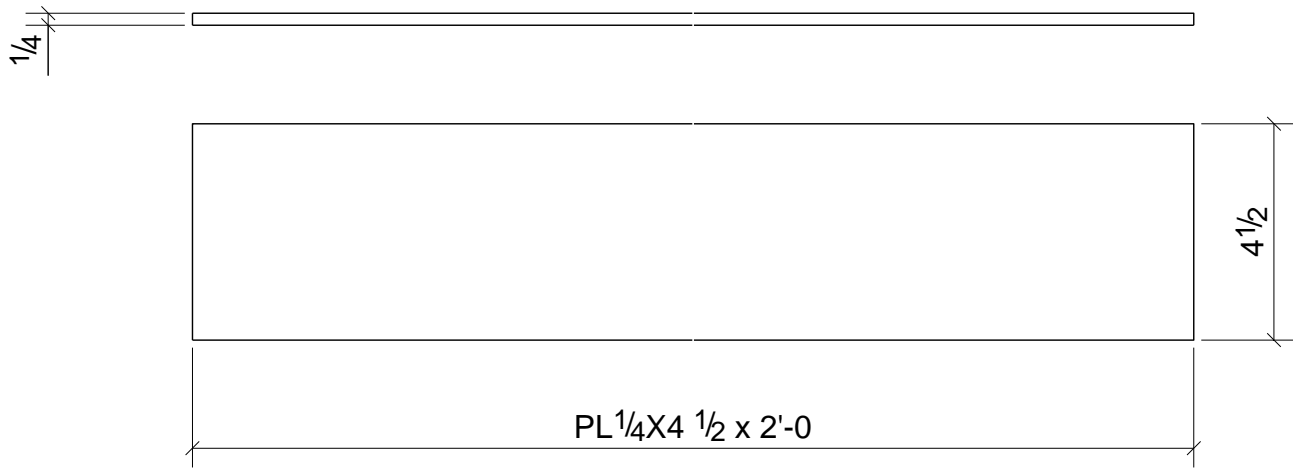

| | | | | | | 1 | 2A |
|----------------------------|---------------|------------------|------|--------|--------|---------------------|-------------|
| | | | | | | Qty. | In Assembly |
| p52 | PL1/4"X4 1/2" | ASTM A240 GR.304 | 1 | 2'-0" | 230 | 8 | |
| MARK | SIZE | GRADE | QTY. | LENGTH | AREA | WEIGHT | |
| MATERIAL LIST FOR WORKSHOP | | | | | TOTALS | 230 in ² | 8 lb/ft |

| | | | | |
|---------------------------------------|-------------|------------|---------------|------------|
| MARTIN'S METAL FABRICATION | DRAWING No. | | p52 | |
| | JOB No. | 210468 | DESCRIPTION | |
| | DRAWN BY | MF | REVISION No. | 1 |
| | DATE DRAWN | 12/16/2021 | REVISION DATE | 01/04/2022 |

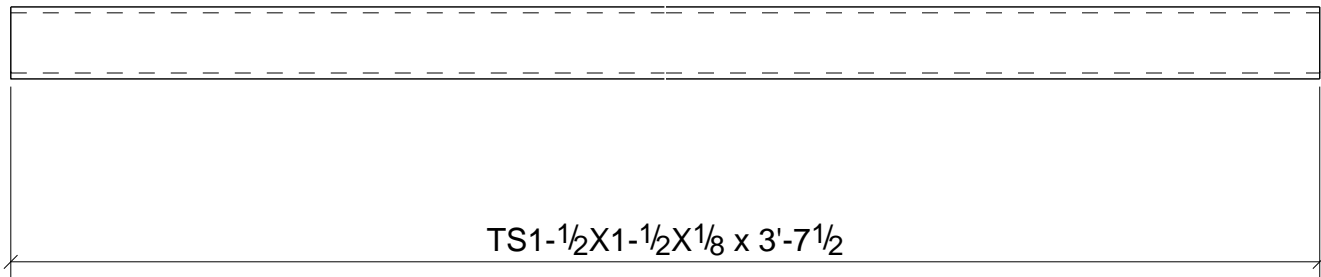

| | |
|------|-------------|
| 4 | 3A |
| 1 | 6A |
| Qty. | In Assembly |

| | | | | | | | |
|----------------------------|-------------------|------------------|------|-----------|--------|----------------------|----------|
| p53 | TS1-1/2X1-1/2X1/8 | ASTM A554 GR.304 | 5 | 3'-7 1/2" | 245 | 8 | |
| MARK | SIZE | GRADE | QTY. | LENGTH | AREA | WEIGHT | |
| MATERIAL LIST FOR WORKSHOP | | | | | TOTALS | 1227 in ² | 38 lb/ft |

| | | | | | |
|---------------------------------------|--------------------|------------|---------------|------------|--|
| MARTIN'S METAL FABRICATION | DRAWING No. | p53 | | | |
| | JOB No. | 210468 | DESCRIPTION | | |
| | DRAWN BY | MF | REVISION No. | 1 | |
| | DATE DRAWN | 12/22/2021 | REVISION DATE | 01/04/2022 | |

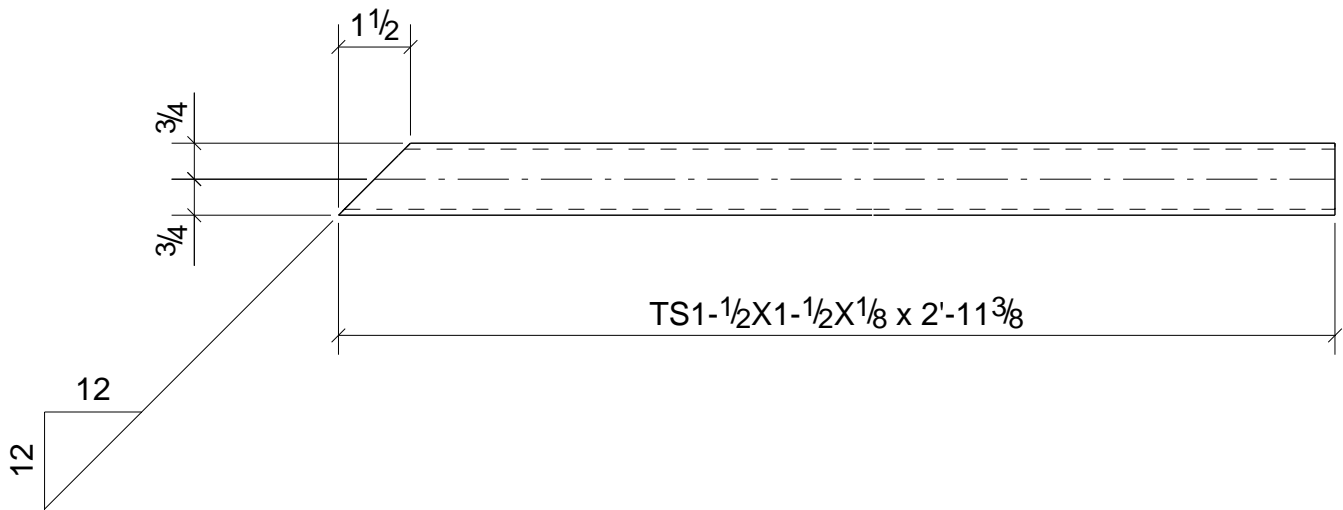

| | | | | | | | |
|----------------------------|-------------------|------------------|------|------------|--------|---------------------|-------------|
| | | | | | | 2 | 3A |
| | | | | | | Qty. | In Assembly |
| p55 | TS1-1/2X1-1/2X1/8 | ASTM A554 GR.304 | 2 | 2'-11 3/8" | 200 | | 6 |
| MARK | SIZE | GRADE | QTY. | LENGTH | AREA | | WEIGHT |
| MATERIAL LIST FOR WORKSHOP | | | | | TOTALS | 399 in ² | 12 lb/ft |

| | | | | |
|---------------------------------------|-------------|------------|---------------|------------|
| MARTIN'S METAL FABRICATION | DRAWING No. | | p55 | |
| | JOB No. | 210468 | DESCRIPTION | |
| | DRAWN BY | MF | REVISION No. | 1 |
| | DATE DRAWN | 12/22/2021 | REVISION DATE | 01/04/2022 |

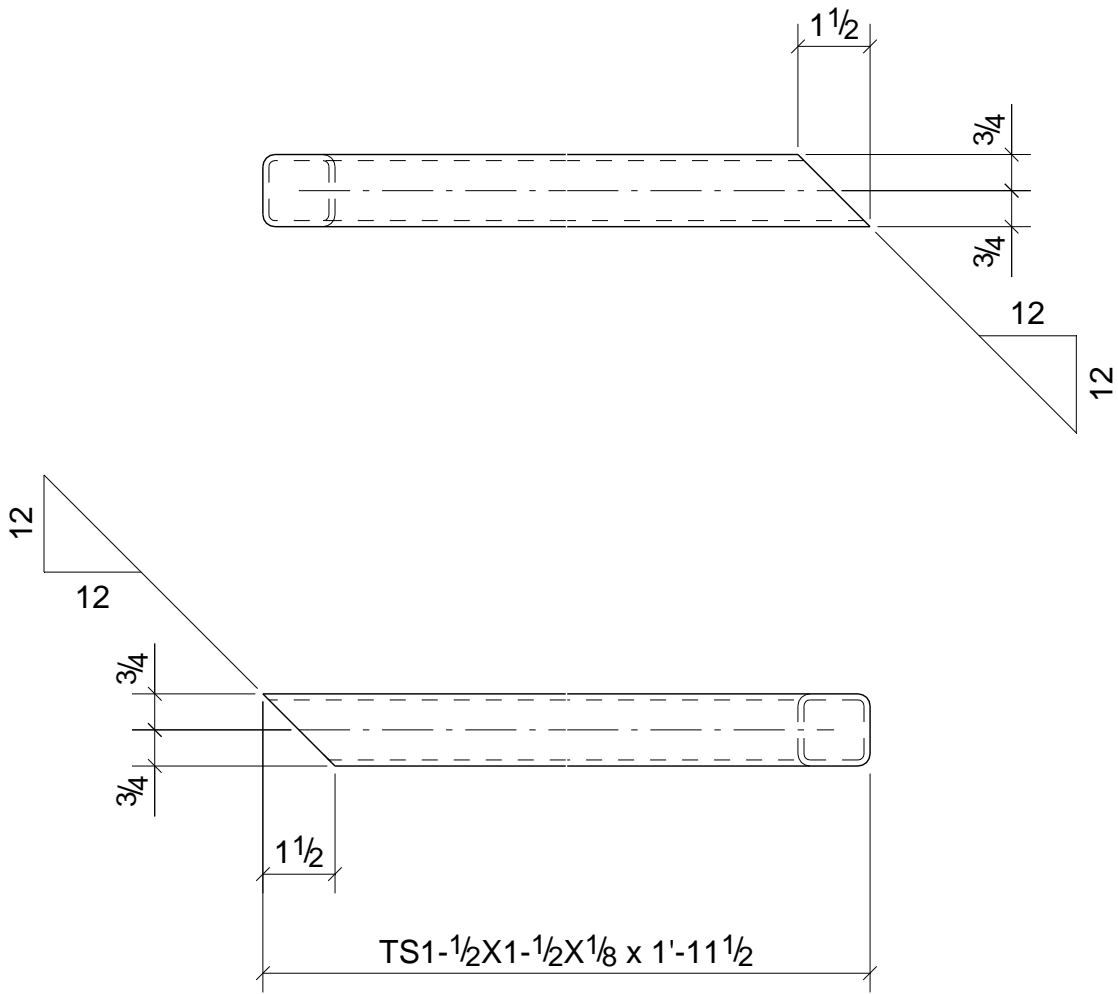

| | | | | | | 1 | 3A |
|----------------------------|-------------------|------------------|------|------------|--------|---------------------|-------------|
| | | | | | | Qty. | In Assembly |
| p56 | TS1-1/2X1-1/2X1/8 | ASTM A554 GR.304 | 1 | 1'-11 1/2" | 133 | 4 | |
| MARK | SIZE | GRADE | QTY. | LENGTH | AREA | WEIGHT | |
| MATERIAL LIST FOR WORKSHOP | | | | | TOTALS | 133 in ² | 4 lb/ft |

| | | | | |
|---------------------------------------|------------------------|------------|---------------|------------|
| MARTIN'S METAL FABRICATION | DRAWING No. p56 | | | |
| | JOB No. | 210468 | DESCRIPTION | |
| | DRAWN BY | MF | REVISION No. | 1 |
| | DATE DRAWN | 12/22/2021 | REVISION DATE | 01/04/2022 |

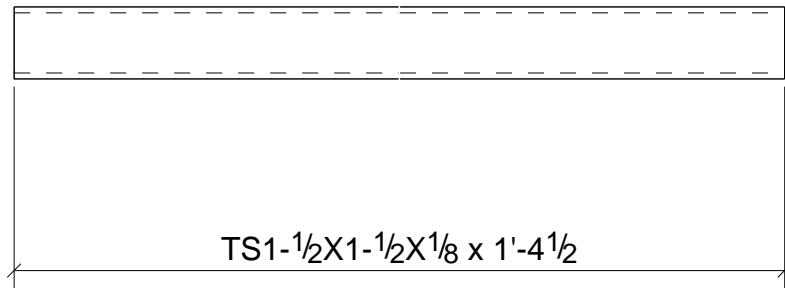

| | | | | | | 1 | 3A |
|----------------------------|-------------------|------------------|------|-----------|--------|--------------------|-------------|
| | | | | | | Qty. | In Assembly |
| p57 | TS1-1/2X1-1/2X1/8 | ASTM A554 GR.304 | 1 | 1'-4 1/2" | 93 | 3 | |
| MARK | SIZE | GRADE | QTY. | LENGTH | AREA | WEIGHT | |
| MATERIAL LIST FOR WORKSHOP | | | | | TOTALS | 93 in ² | 3 lb/ft |

| | | | | |
|---------------------------------------|-------------|------------|---------------|------------|
| MARTIN'S METAL FABRICATION | DRAWING No. | | p57 | |
| | JOB No. | 210468 | DESCRIPTION | |
| | DRAWN BY | MF | REVISION No. | 1 |
| | DATE DRAWN | 12/22/2021 | REVISION DATE | 01/04/2022 |

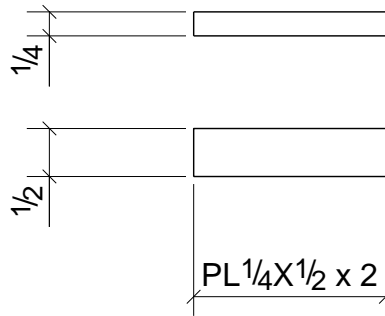

| | |
|------|-------------|
| 5 | 3A |
| 1 | 6A |
| Qty. | In Assembly |

| | | | | | | | |
|----------------------------|-------------|------------------|------|--------|--------|--------------------|---------|
| p59 | PL1/4"X1/2" | ASTM A240 GR.304 | 6 | 0'-2" | 3 | 0 | |
| MARK | SIZE | GRADE | QTY. | LENGTH | AREA | WEIGHT | |
| MATERIAL LIST FOR WORKSHOP | | | | | TOTALS | 20 in ² | 0 lb/ft |

| | | | | | | |
|---------------------------------------|-------------|------------|---------------|--|------------|--|
| MARTIN'S METAL FABRICATION | DRAWING No. | | p59 | | | |
| | JOB No. | 210468 | DESCRIPTION | | | |
| | DRAWN BY | MF | REVISION No. | | 1 | |
| | DATE DRAWN | 12/22/2021 | REVISION DATE | | 01/04/2022 | |

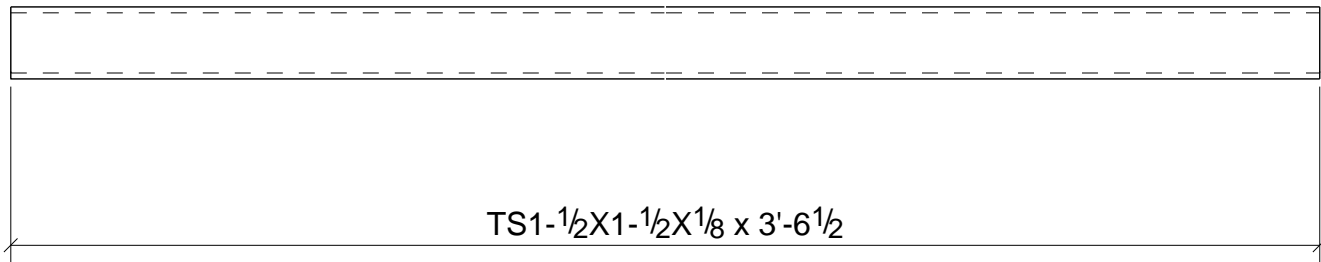

| | | | | | | 1 | 6A |
|---------------------------------------|-------------------|------------------|-------------|------------|---------------|---------------------|-------------|
| | | | | | | Qty. | In Assembly |
| p60 | TS1-1/2X1-1/2X1/8 | ASTM A554 GR.304 | 1 | 3'-6 1/2" | 240 | 7 | |
| MARK | SIZE | GRADE | QTY. | LENGTH | AREA | WEIGHT | |
| MATERIAL LIST FOR WORKSHOP | | | | | TOTALS | 240 in ² | 7 lb/ft |
| MARTIN'S METAL FABRICATION | | | DRAWING No. | | p60 | | |
| | | | JOB No. | 210468 | DESCRIPTION | | |
| | | | DRAWN BY | MF | REVISION No. | 1 | |
| | | | DATE DRAWN | 12/22/2021 | REVISION DATE | 01/04/2022 | |

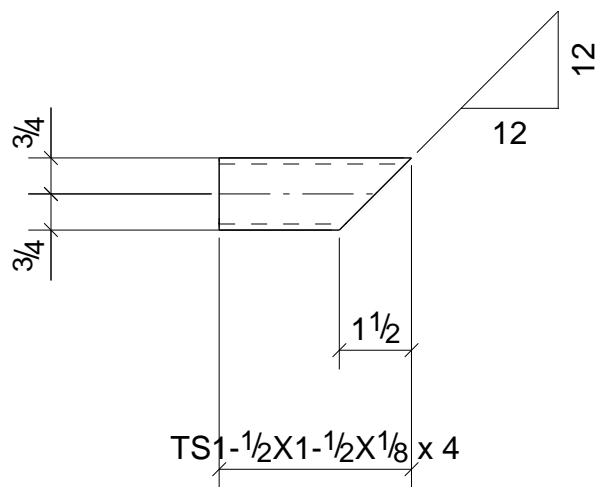

| | |
|------|-------------|
| 1 | 3A |
| 2 | 6A |
| Qty. | In Assembly |

| | | | | | | | |
|----------------------------|-------------------|------------------|------|--------|--------|--------------------|---------|
| p61 | TS1-1/2X1-1/2X1/8 | ASTM A554 GR.304 | 3 | 0'-4" | 23 | 1 | |
| MARK | SIZE | GRADE | QTY. | LENGTH | AREA | WEIGHT | |
| MATERIAL LIST FOR WORKSHOP | | | | | TOTALS | 68 in ² | 2 lb/ft |

| | | | |
|---------------------------------------|------------------------|---------------|------------|
| MARTIN'S METAL FABRICATION | DRAWING No. p61 | | |
| | JOB No. | 210468 | |
| | DRAWN BY | MF | |
| | DATE DRAWN | 12/22/2021 | |
| | | DESCRIPTION | |
| | | REVISION No. | 1 |
| | | REVISION DATE | 01/04/2022 |

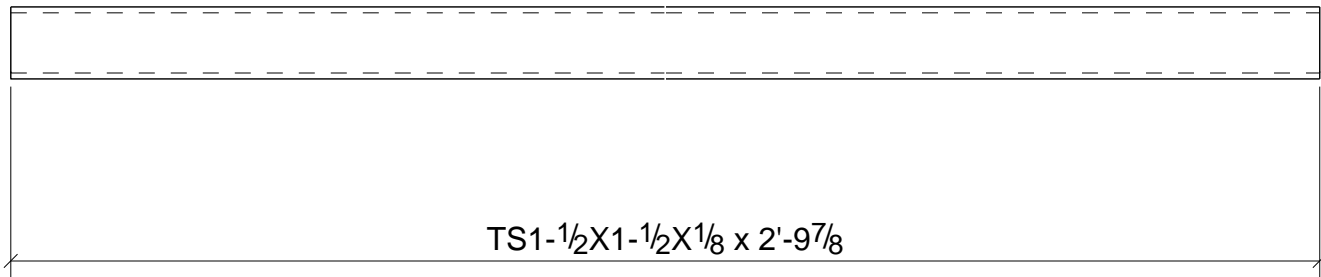

| | | | | | | | |
|---------------------------------------|-------------------|------------------|-------------|------------|---------------|---------------------|-------------|
| | | | | | | 2 | 3A |
| | | | | | | Qty. | In Assembly |
| p62 | TS1-1/2X1-1/2X1/8 | ASTM A554 GR.304 | 2 | 2'-9 7/8" | 191 | 6 | |
| MARK | SIZE | GRADE | QTY. | LENGTH | AREA | WEIGHT | |
| MATERIAL LIST FOR WORKSHOP | | | | | TOTALS | 382 in ² | 12 lb/ft |
| MARTIN'S METAL FABRICATION | | | DRAWING No. | | p62 | | |
| | | | JOB No. | 210468 | DESCRIPTION | | |
| | | | DRAWN BY | MF | REVISION No. | 1 | |
| | | | DATE DRAWN | 12/22/2021 | REVISION DATE | 01/04/2022 | |

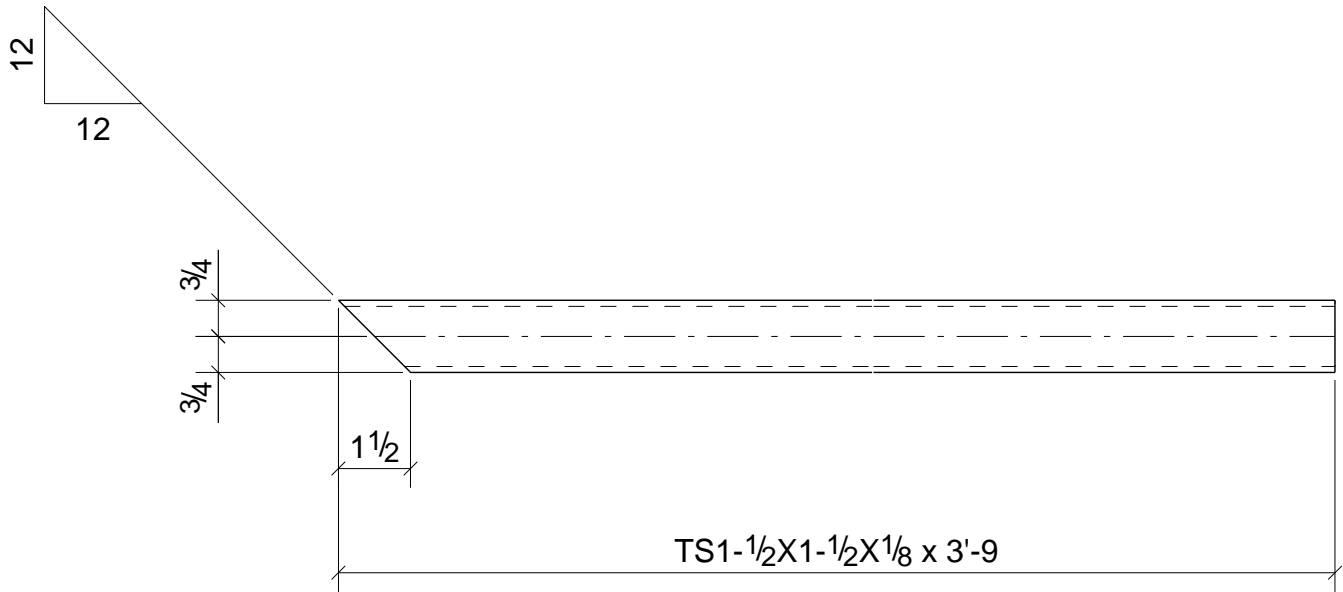

| | | | | | | 1 | 3A |
|----------------------------|-------------------|------------------|------|--------|---------------------|---------|-------------|
| | | | | | | Qty. | In Assembly |
| p63 | TS1-1/2X1-1/2X1/8 | ASTM A554 GR.304 | 1 | 3'-9" | 254 | 8 | |
| MARK | SIZE | GRADE | QTY. | LENGTH | AREA | WEIGHT | |
| MATERIAL LIST FOR WORKSHOP | | | | TOTALS | 254 in ² | 8 lb/ft | |

| | | | | | | |
|---------------------------------------|-------------|------------|---------------|--|------------|--|
| MARTIN'S METAL FABRICATION | DRAWING No. | | p63 | | | |
| | JOB No. | 210468 | DESCRIPTION | | | |
| | DRAWN BY | MF | REVISION No. | | 1 | |
| | DATE DRAWN | 12/22/2021 | REVISION DATE | | 01/04/2022 | |

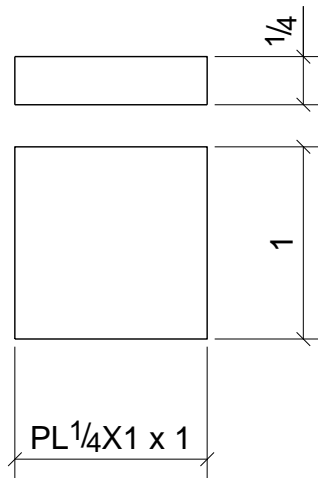

| | | | | | | 1 | 6A |
|----------------------------|-----------|------------------|------|--------|--------|-------------------|-------------|
| | | | | | | Qty. | In Assembly |
| p64 | PL1/4"X1" | ASTM A240 GR.304 | 1 | 0'-1" | 3 | 0 | |
| MARK | SIZE | GRADE | QTY. | LENGTH | AREA | WEIGHT | |
| MATERIAL LIST FOR WORKSHOP | | | | | TOTALS | 3 in ² | 0 lb/ft |

| | | | | |
|---------------------------------------|-------------|------------|---------------|------------|
| MARTIN'S METAL FABRICATION | DRAWING No. | | p64 | |
| | JOB No. | 210468 | DESCRIPTION | |
| | DRAWN BY | MF | REVISION No. | 1 |
| | DATE DRAWN | 12/22/2021 | REVISION DATE | 01/04/2022 |

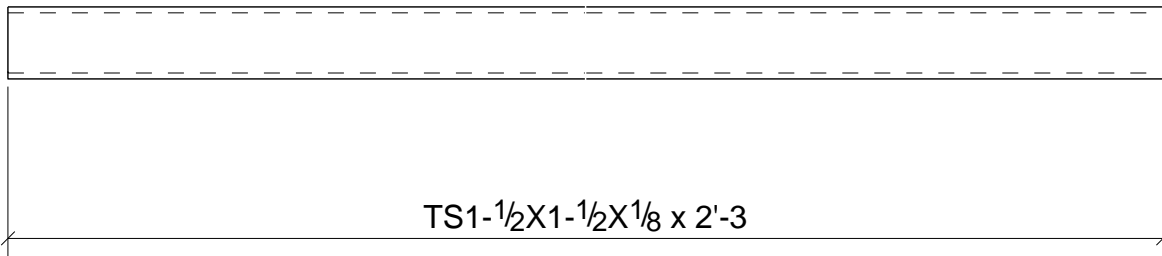

| | | | | | | 1 | 6A | |
|----------------------------|-------------------|------------------|------|--------|--|--------|---------------------|---------|
| | | | | | | Qty. | In Assembly | |
| p65 | TS1-1/2X1-1/2X1/8 | ASTM A554 GR.304 | 1 | 2'-3" | | 152 | 5 | |
| MARK | SIZE | GRADE | QTY. | LENGTH | | AREA | WEIGHT | |
| MATERIAL LIST FOR WORKSHOP | | | | | | TOTALS | 152 in ² | 5 lb/ft |

| | | | | |
|---------------------------------------|--------------------|------------|---------------|------------|
| MARTIN'S METAL FABRICATION | DRAWING No. | | p65 | |
| | JOB No. | 210468 | DESCRIPTION | |
| | DRAWN BY | MF | REVISION No. | 1 |
| | DATE DRAWN | 12/22/2021 | REVISION DATE | 01/04/2022 |

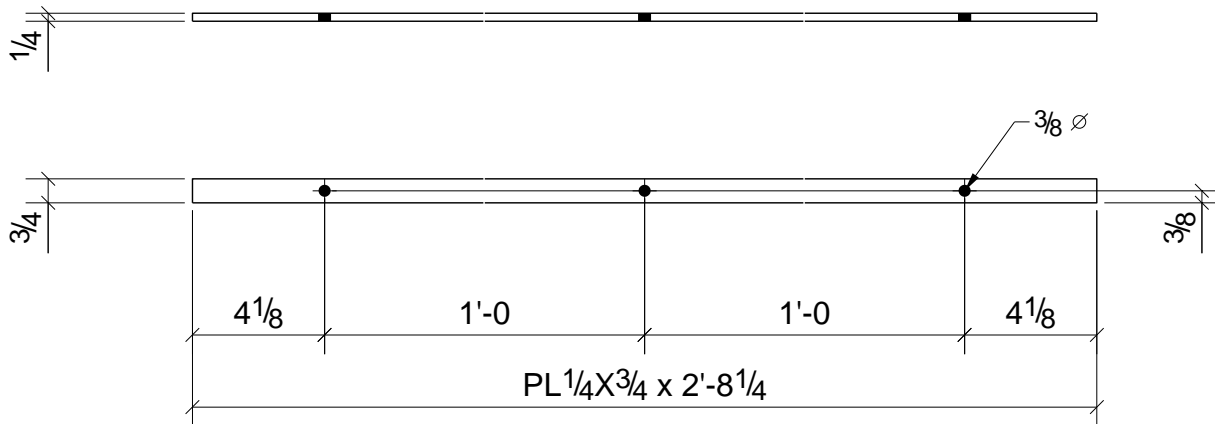

| | | | | | | | |
|----------------------------|-------------|------------------|------|-----------|--------|---------------------|-------------|
| | | | | | | 3 | 2A |
| | | | | | | Qty. | In Assembly |
| p66 | PL1/4"X3/4" | ASTM A240 GR.304 | 3 | 2'-8 1/4" | | 65 | 2 |
| MARK | SIZE | GRADE | QTY. | LENGTH | | AREA | WEIGHT |
| MATERIAL LIST FOR WORKSHOP | | | | | TOTALS | 195 in ² | 5 lb/ft |

| | | | | |
|---------------------------------------|-------------|------------|---------------|------------|
| MARTIN'S METAL FABRICATION | DRAWING No. | | p66 | |
| | JOB No. | 210468 | DESCRIPTION | |
| | DRAWN BY | MF | REVISION No. | 1 |
| | DATE DRAWN | 01/04/2022 | REVISION DATE | 01/04/2022 |

1/4

2'-8 1/4

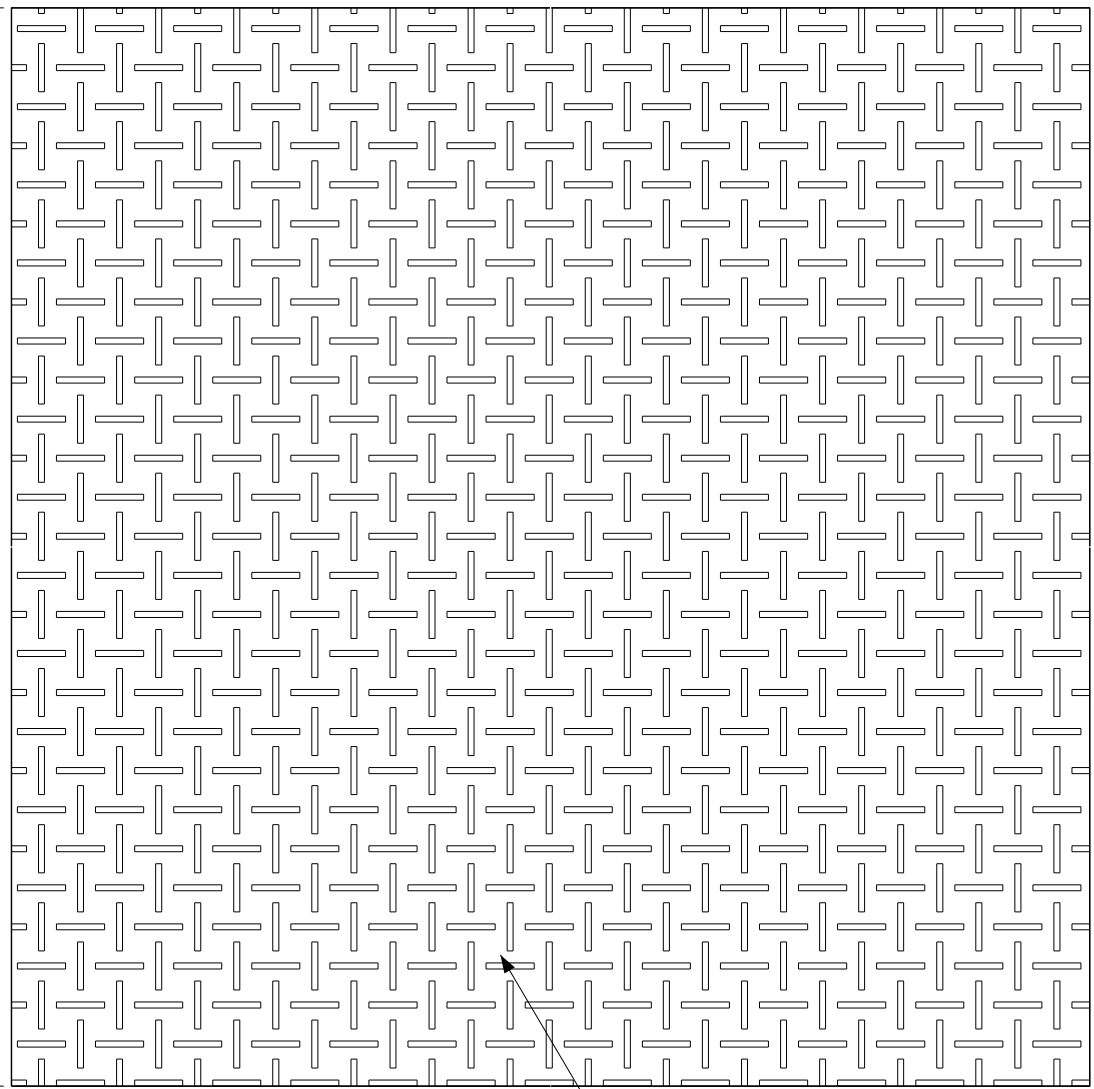

CHECKERED
NS

CHKPL 1/4 X 32 1/4 x 2'-11 1/4

| | | | | | | | |
|----------------------------|----------------------|------------------|------|------------|--------|----------------------|-------------|
| p74 | CHKPL 1/4" X 32 1/4" | ASTM A240 GR.304 | 2 | 2'-11 1/4" | 2307 | 2 | 2A |
| | | | | | | Qty. | In Assembly |
| MARK | SIZE | GRADE | QTY. | LENGTH | AREA | WEIGHT | |
| MATERIAL LIST FOR WORKSHOP | | | | | TOTALS | 4615 in ² | 161 lb/ft |

| | | | | |
|-------------------------------|-------------|------------|---------------|------------|
| MARTIN'S METAL FABRICATION | DRAWING No. | | p74 | |
| | JOB No. | 210468 | DESCRIPTION | |
| | DRAWN BY | MF | REVISION No. | 1 |
| | DATE DRAWN | 01/04/2022 | REVISION DATE | 01/04/2022 |

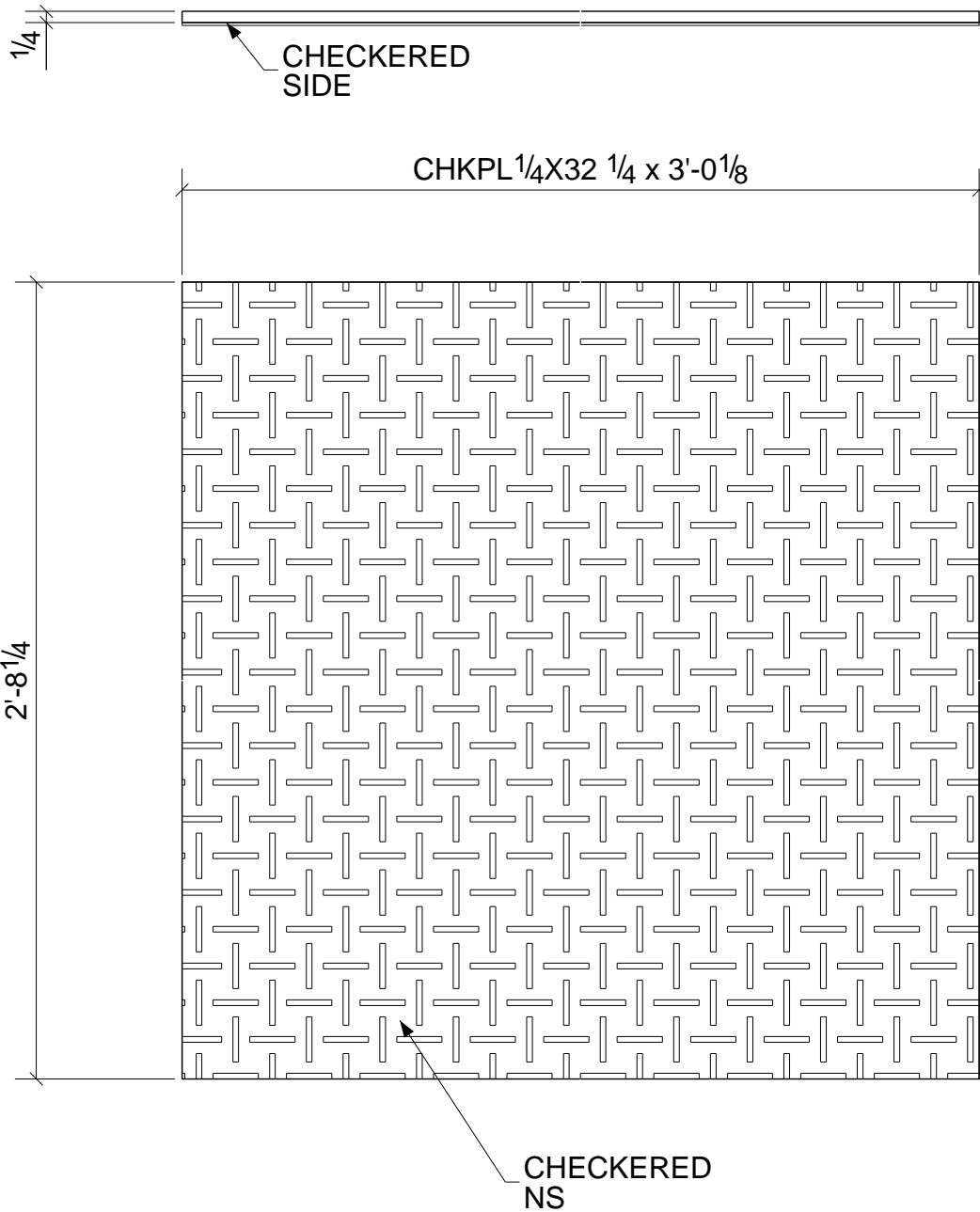

| | | | | | | 1 | 2A |
|----------------------------|----------------------|------------------|------|-----------|--------|----------------------|-------------|
| | | | | | | Qty. | In Assembly |
| p75 | CHKPL 1/4" X 32 1/4" | ASTM A240 GR.304 | 1 | 3'-0 1/8" | 2364 | 83 | |
| MARK | SIZE | GRADE | QTY. | LENGTH | AREA | WEIGHT | |
| MATERIAL LIST FOR WORKSHOP | | | | | TOTALS | 2364 in ² | 83 lb/ft |

| | | | | |
|---------------------------------------|------------------------|------------|---------------|------------|
| MARTIN'S METAL FABRICATION | DRAWING No. p75 | | | |
| | JOB No. | 210468 | DESCRIPTION | |
| | DRAWN BY | MF | REVISION No. | 1 |
| | DATE DRAWN | 01/04/2022 | REVISION DATE | 01/04/2022 |

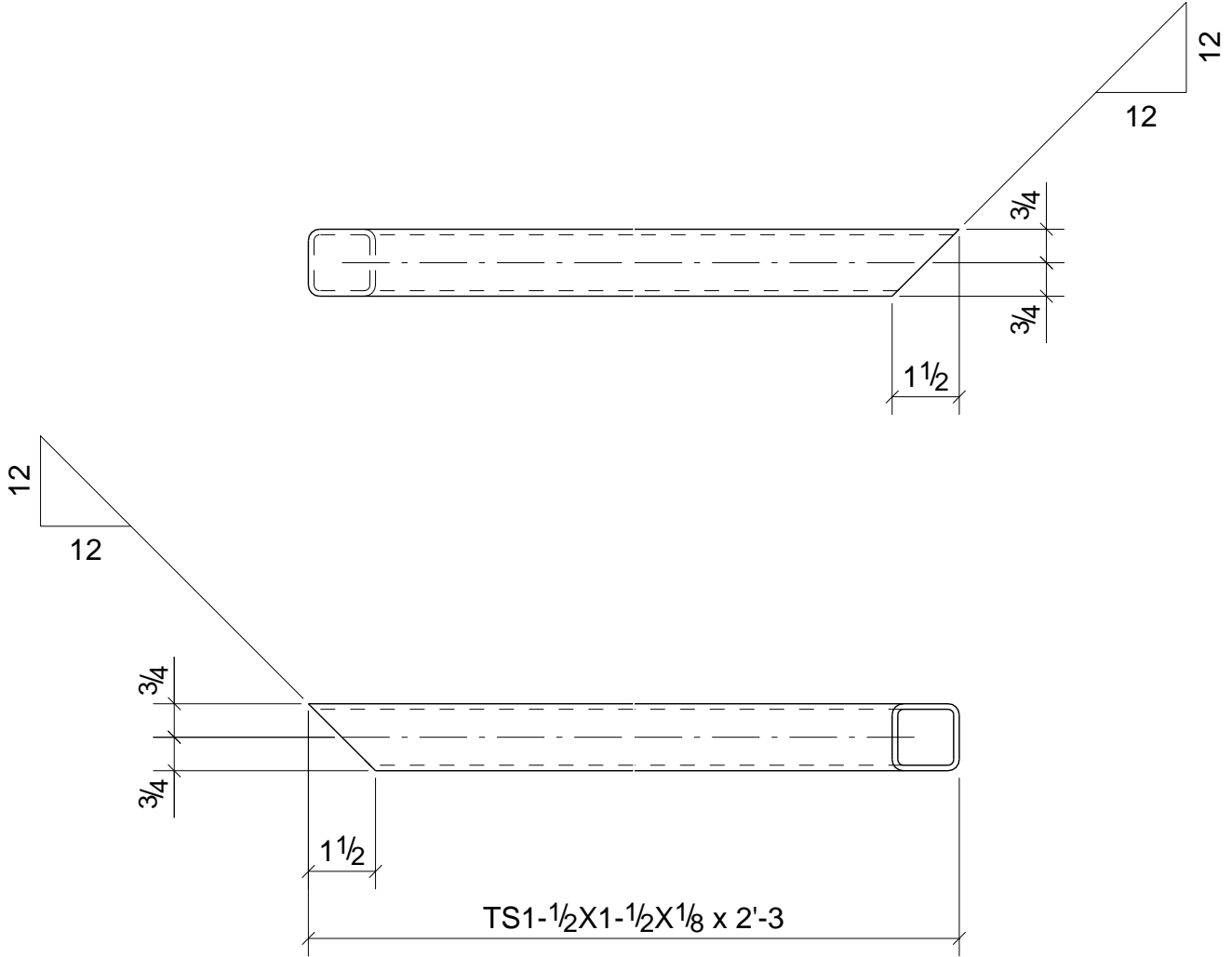

| | | | | | | |
|----------------------------|-------------------|------------------|------|--------|---------------------|---------|
| p76 | TS1-1/2X1-1/2X1/8 | ASTM A554 GR.304 | 1 | 2'-3" | 152 | 5 |
| MARK | SIZE | GRADE | QTY. | LENGTH | AREA | WEIGHT |
| MATERIAL LIST FOR WORKSHOP | | | | TOTALS | 152 in ² | 5 lb/ft |

| | |
|------|-------------|
| 1 | 6A |
| Qty. | In Assembly |

| | | |
|---------------------------------------|------------------------|--------------------------|
| MARTIN'S METAL FABRICATION | DRAWING No. p76 | |
| | JOB No. 210468 | DESCRIPTION |
| | DRAWN BY MF | REVISION No. 1 |
| | DATE DRAWN 01/04/2022 | REVISION DATE 01/04/2022 |

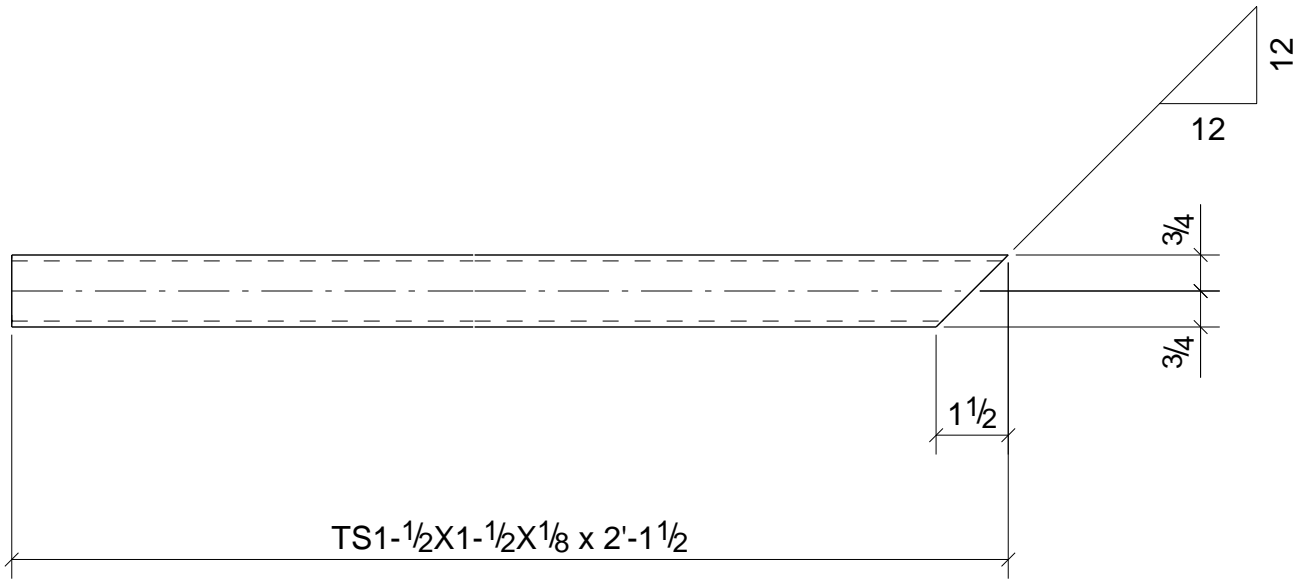

| | | | | | | 1 | 6A |
|----------------------------|-------------------|------------------|------|-----------|--------|---------------------|-------------|
| | | | | | | Qty. | In Assembly |
| p77 | TS1-1/2X1-1/2X1/8 | ASTM A554 GR.304 | 1 | 2'-1 1/2" | 144 | 4 | |
| MARK | SIZE | GRADE | QTY. | LENGTH | AREA | WEIGHT | |
| MATERIAL LIST FOR WORKSHOP | | | | | TOTALS | 144 in ² | 4 lb/ft |

| | | | | |
|---------------------------------------|-------------|------------|---------------|------------|
| MARTIN'S METAL FABRICATION | DRAWING No. | | p77 | |
| | JOB No. | 210468 | DESCRIPTION | |
| | DRAWN BY | MF | REVISION No. | 1 |
| | DATE DRAWN | 01/04/2022 | REVISION DATE | 01/04/2022 |

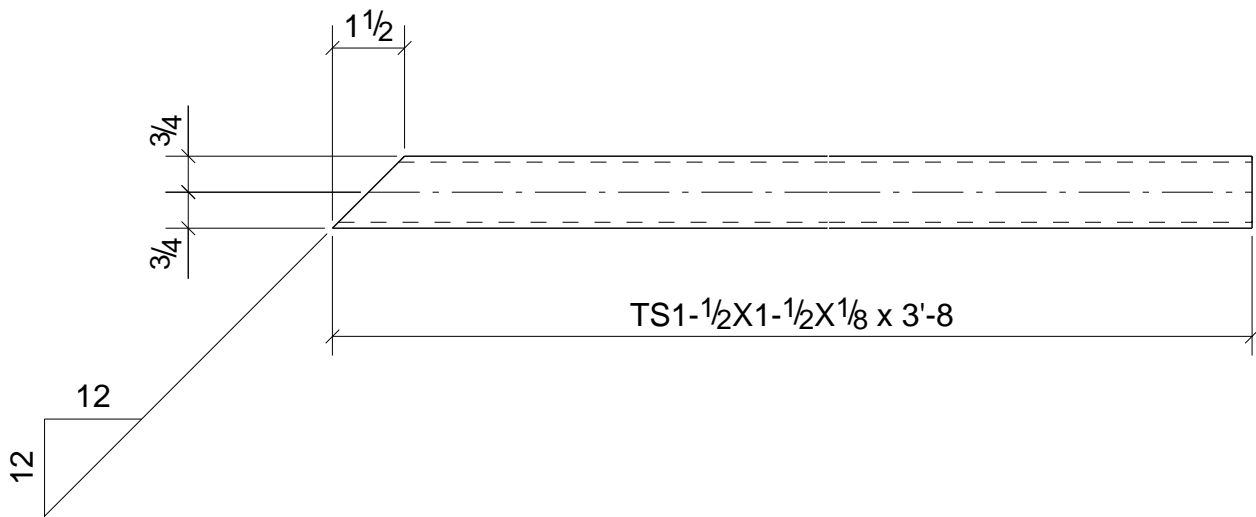

| | | | | | | 1 | 6A |
|----------------------------|-------------------|------------------|------|--------|--------|---------------------|-------------|
| | | | | | | Qty. | In Assembly |
| p78 | TS1-1/2X1-1/2X1/8 | ASTM A554 GR.304 | 1 | 3'-8" | 248 | 8 | |
| MARK | SIZE | GRADE | QTY. | LENGTH | AREA | WEIGHT | |
| MATERIAL LIST FOR WORKSHOP | | | | | TOTALS | 248 in ² | 8 lb/ft |

| | | | | |
|---------------------------------------|-------------|------------|---------------|------------|
| MARTIN'S METAL FABRICATION | DRAWING No. | | p78 | |
| | JOB No. | 210468 | DESCRIPTION | |
| | DRAWN BY | MF | REVISION No. | 1 |
| | DATE DRAWN | 01/04/2022 | REVISION DATE | 01/04/2022 |